

# KITCHEN ATMOSPHERE

**Euromobil**



## KITCHEN ATMOSPHERE

La buona cucina italiana dove  
cultura del progetto e qualità dei materiali  
esaltano il made in Italy  
in una dimensione internazionale:  
un viaggio attraverso tredici atmosfere  
dalle architetture emozionanti.

Attractive Italian kitchens bring together  
design culture and quality materials  
to exalt the international dimension  
of Italian made furniture:  
a whirl through thirteen atmospheres  
featuring exciting architecture.

DESIGN R&S EUROMOBIL E ROBERTO GOBBO

**KITCHEN ATMOSPHERE**

pag. 04

**KITCHEN SYSTEM**

pag. 168

**KITCHEN TECH**

pag. 222

TELERO 01



pag. 06



pag. 20



pag. 30



pag. 40

ANTIS 05



pag. 50



pag. 64



pag. 78

FILÒ 08



pag. 94

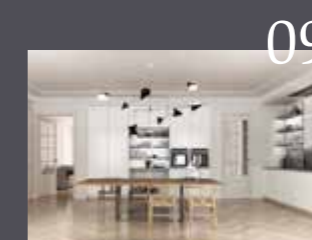

pag. 110



pag. 120

KUBIC 11



pag. 132



pag. 144

FREE STEEL 13



pag. 156

# KITCHEN ATMOSPHERE

The Cool Couple, Niccolò Benetton e Simone Santilli, "General Krasnov's residence", Verzegnis #001 A/B, 2013.  
Premio Gruppo Euromobil Under 30, undicesima edizione, Arte Fiera Bologna 2017.  
Il dittico fotografico rievoca una tragica vicenda della seconda guerra mondiale rivissuta attraverso le immagini suggestive e piene della densa crosta formatasi all'interno del grande camino nella casa che ospitò il generale Krasnov a Verzegnis. L'aspetto biografico diventa metafora della sedimentazione di una memoria che da personale diventa universale e da occasionale diventa eterna.

The Cool Couple, Niccolò Benetton and Simone Santilli, 'General Krasnov's Residence', Verzegnis #001 A/B, 2013.  
Eleventh edition of the Premio Gruppo Euromobil Under 30 at the 2017 Arte Fiera Bologna.  
This photographic diptych recalls a tragic event of the Second World War, brought back to mind by evocative images filled with the dense encrustations inside the large fireplace in the house at Verzegnis where General Krasnov was posted. The biographical aspect becomes a metaphor of a solidified memory, first of all personal and then universal, going from occasional to eternal.

## TELERO

« Raffinata contaminazione progettuale con sette originali palette materico-cromatiche che consentono progetti personalizzati. Telaio in alluminio anodizzato con lavorazione millerighe e pannelli multimateriale.

Refined design contamination with seven original texture-colour palettes to create customised projects. Finely striped, anodised aluminium frame and multimaterial panels. »







Atmosfera elegante e funzionalità  
 marcata con la leggera e resistente  
 anta, struttura alluminio e pannello in  
 vetro entrambi in nero assoluto opaco.

An elegant atmosphere and great  
 functionality set off by a strong,  
 uncluttered door, aluminium structure and  
 glass panel, both in mat absolut black.







Cassetti e cestone Cube grafite completi di accessori. A sinistra, anta Telero con telaio in alluminio anodizzato sp.16,5 mm con lavorazione millerighe e pannello in vetro temprato sp.4 mm, funzionale profilo maniglia superiore.  
 Cube graphite drawers and deep drawers, with accessories. On the left, the Telero door with 16,5 mm anodised, finely striped aluminium frame, 4 mm thick tempered glass panel and practical upper groove profile.





# 01 atmosphere TELERO

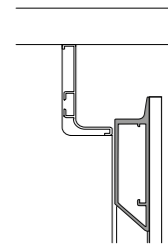

## FIL033

gola con frontali  
lato maniglia  
sagomato  
groove profile  
with shaped  
handle fronts

## 1 TELERO

Telaio nero assoluto, ante basi, colonne e coprifianchi vetro laccato nero assoluto opaco. Profilo gola e zoccolo h.8 cm alluminio laccato nero assoluto opaco. Piano top in vetro nero assoluto opaco sp.12 mm e cappa integrata nel piano cottura.

Frame in absolut black, doors for base units, tall units and finishing panels in mat absolut black lacquered glass. Groove profile and plinth h.8 cm mat absolut black lacquered aluminium. Top in mat absolut black glass th.12 mm and hob integrated hood.

## 2 FRAME

Pensili telaio nero e vetro fumé con cornice laccato nero assoluto opaco.

Wall unit with black chassis and fumé glass with mat absolut black lacquered frame.

## 3 HORIZON

Boiserie e mensole in termostrutturato materico rovere Ontario, elemento scorrevole in laccato nero assoluto opaco.

Boiserie and shelves in thermostructured textured Ontario oak, mat absolut black lacquered sliding element.

## 4 THIN

Tavolo snack laccato nero assoluto opaco.

Mat absolut black lacquered snack table.

BASI E COLONNE / BASE UNITS AND TALL UNITS



vetro laccato nero assoluto opaco  
mat absolut black lacquered glass

BOISERIE / BOISERIE



termostrutturato materico rovere ontario  
thermostructured textured Ontario oak

PENSILI / WALL UNITS

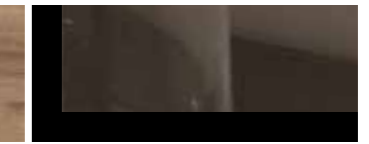

vetro fumé con cornice laccato nero assoluto opaco  
fumé glass with absolut black mat lacquered frame

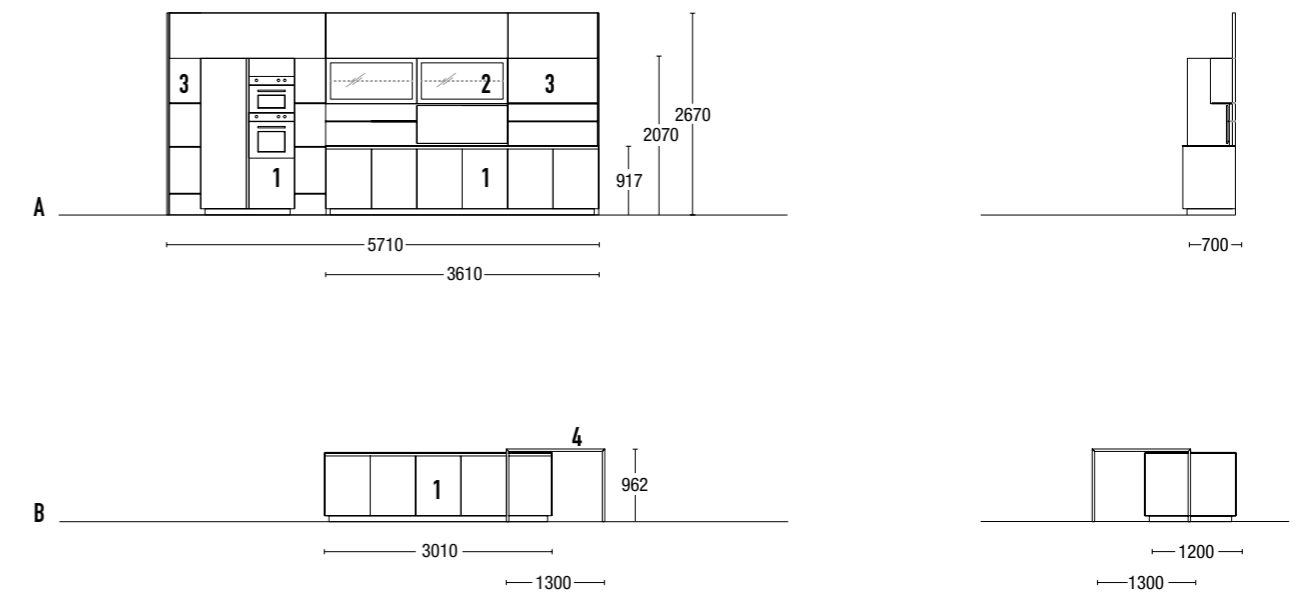
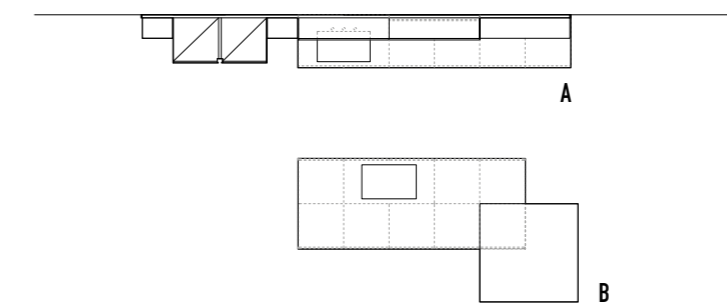





Estetica lineare, volumi monolitici e mood razionalista impreziositi da vibranti finiture materiche.

Linear styling, monolith volumes and rational mood enhanced by vibrant textured finishes.



Organizzare razionalmente lo spazio con la capiente colonna frigorifero e congelatore da L.76,2 cm. A destra, canale attrezzato Gap e cappa integrata.  
 Rational space organisation with a large tall unit for a fridge and L.76,2 cm freezer. On the right, Gap kitchen rack and integrated hood.

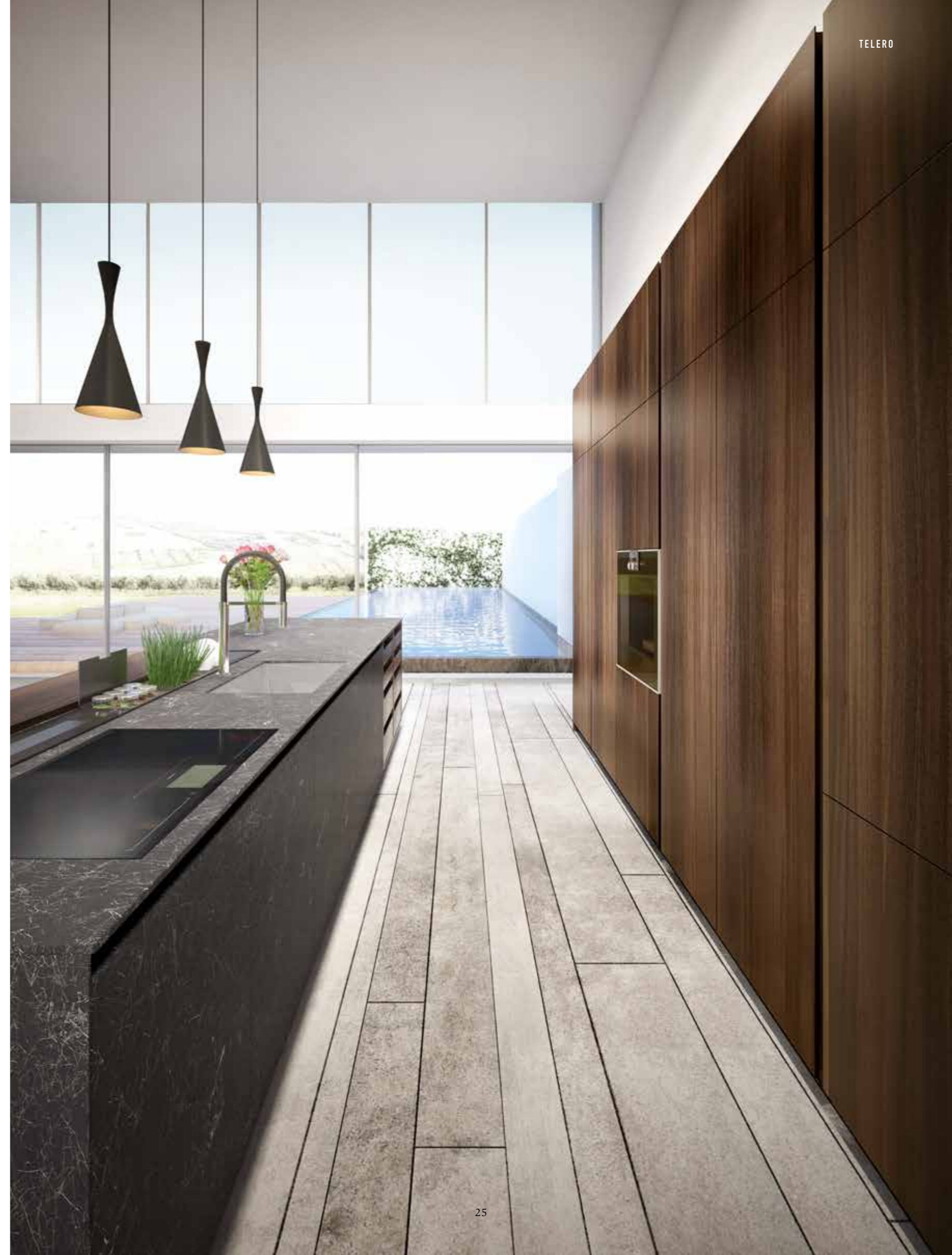





02  
atmosphere  
TELERO

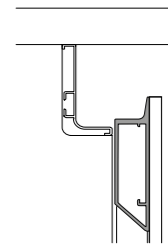

**FILO33**

gola con frontali  
lato maniglia  
sagomato  
groove profile  
with shaped  
handle fronts

**1 TELERO**

Ante basi e coprifianchi telaio  
nero assoluto e gres porcellanato  
Laminam nero greco, colonne  
eucalipto termotrattato. Profilo  
gola e zoccolo isola h.8 cm  
alluminio laccato nero assoluto  
opaco, colonne h.8 cm alluminio  
eucalipto termotrattato.  
Piano top in gres porcellanato  
Laminam nero greco sp.12 mm  
e cappa Down-draft su Gap.

Doors for base units and finishing  
panels, absolut black frame and  
porcelain gres top, Greek black  
Laminam, tall units in thermotreated  
eucalypt. Groove profile and plinth  
for island h.8 cm mat absolut black  
lacquered aluminium, h.8 cm tall  
units in thermotreated eucalypt  
aluminium. Top in porcelain gres  
th.12 mm Greek black Laminam  
and Down-draft hood on Gap.

**2 OPEN**

Basi con cassetti eucalipto  
termotrattato.

Base units with drawers  
in thermotreated eucalypt.

**3 GAP**

Canale attrezzato in alluminio  
laccato opaco nero a filotop  
con cappa integrata.

Kitchen rack in black mat  
lacquered aluminium, flush  
with integrated hood.

**4 CABINET**

Colonna monoblocco eucalipto  
termotrattato con attrezzatura  
interna.

Monobloc tall unit in  
thermotreated eucalypt  
with interior fittings.

**5 PAK**

Piano snack eucalipto  
termotrattato.

Snack top in thermotreated  
eucalypt.

BASI / CABINET



gres porcellanato laminam nero greco  
porcelain gres greek black Laminam

COLONNE / TALL UNITS



eucalipto termotrattato  
thermotreated eucalypt

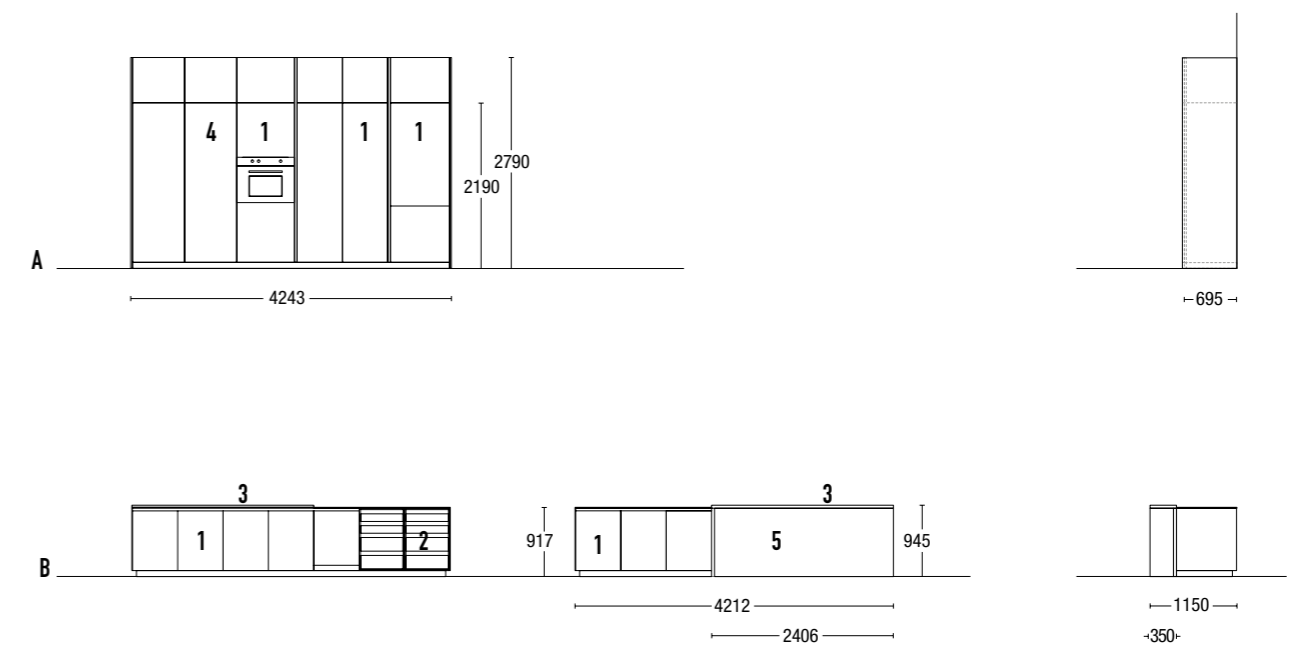
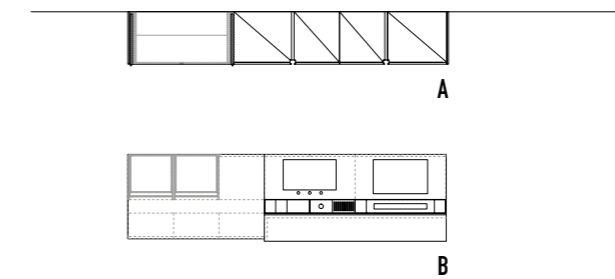



atmosphere 03



Una cucina che riesce in modo armonico a coordinare differenti soluzioni estetiche e funzionali, protagonista sia in grandi che equilibrati spazi.  
Kitchen furniture that harmonically coordinates different aesthetics and functions, ideal where space is abundant or at a premium.





Tutto ciò che serve a portata di mano con i cestoni e cassetti Cube grafite e la base angolo con meccanismo estraibile Magic Corner Kesseböhmer finitura antracite.

Everything you need to hand with Cube graphite drawers and deep drawers and a corner base unit with Kesseböhmer Magic Corner pull-out mechanism with anthracite finish.

03  
atmosphere  
TELERO

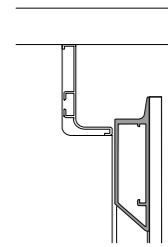

**FIL033**

gola con frontali  
lato maniglia  
sagomato  
groove profile  
with shaped  
handle fronts

**1 TELERO**

Ante basi e colonne telaio titanio e frontali vetro laccato bianco ottico opaco, coprifianchi vetro laccato bianco ottico opaco. Pensili telaio titanio e rovere materia Giza. Profilo gola alluminio finitura acciaio e zoccolo h.8 cm alluminio laccato bianco ottico opaco. Piano top gres porcellanato Laminam bianco lasa sp.20 mm. Cappa integrata su pensile. Piano snack sospeso, inclinato su 4 lati, in rovere materia Giza.

**2 SPACE**

Schienale attrezzato in alluminio finitura titanio e schienale rovere materia Giza.

**3 SNACK WORKTOP**

Piano snack in rovere materia Giza.

Doors for base units and tall units, frame in titanium with mat optic white lacquered glass fronts, finishing panels in mat optic white lacquered glass. Wall units with frame in titanium and Giza materia oak. Groove profile in steel finish aluminium and h.8 cm plinth in mat optic white lacquered aluminium. Th.20 mm top in porcelain gres Laminam lasa white. Hood integrated in the wall unit. Suspended snack top, inclined on 4 sides, in Giza materia oak.

Equipped back panel in titanium finish aluminium and back panel in Giza materia oak.

Snack top in Giza materia oak.

BASI E COLONNE / BASE UNITS AND TALL UNITS    PENSILI E SPACE / WALL UNITS AND SPACE

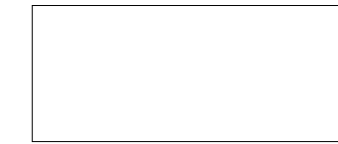

vetro laccato bianco ottico opaco  
mat optic white lacquered glass



rovere materia giza  
giza materia oak

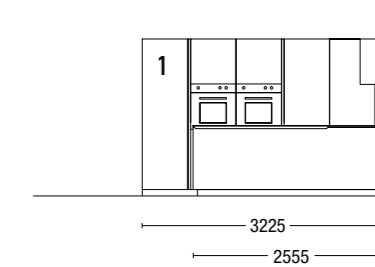
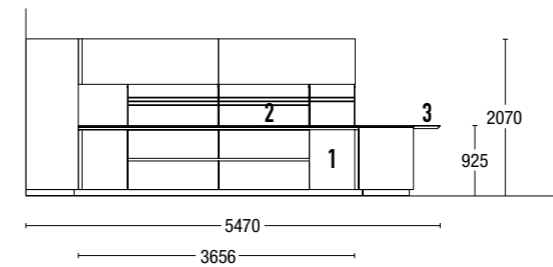
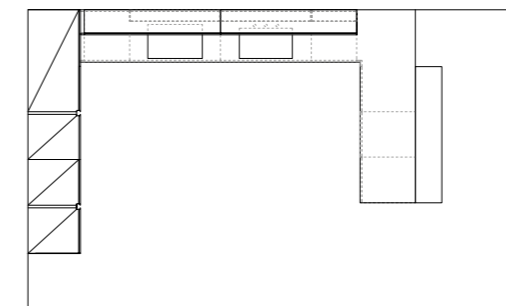



atmosphere 04



Volumi essenziali per uno spazio aperto con la cucina protagonista e il sistema living coordinato nelle forme e nei materiali. Finitura Satin laccata effetto metallo realizzata con sei passaggi manuali su ogni lato.

Essential dimensions for an open concept kitchen and living room system in coordinated shapes and materials. Metal effect Satin lacquered finish is achieved by manually applying six coats to each side.









# 04 atmosphere TELERO

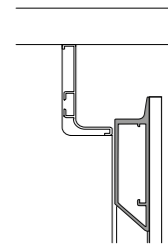

## FIL033

gola con frontali lato maniglia sagomato  
groove profile with shaped handle fronts

### 1 TELERO

Ante basi e colonne telaio titanio e laccato Satin nichel, coprifianchi laccato Satin nichel. Profilo gola alluminio laccato titanio e zoccolo h.8 cm alluminio laccato nichel. Piano top in quarzo sand sp.20 mm e cappa isola acciaio e laccato nero.

Doors for base units and tall units with titanium frame and nickel Satin lacquered, nickel Satin lacquered finishing panels. Titanium lacquered aluminium groove profile and h.8 cm plinth in nickel lacquered aluminium. Th.20 mm sand Quartz top and island hood in black lacquered steel.

### 2 TECA

Pensili telaio testa di moro e vetro fumé.

Wall units with dark brown frame and fumé glass.

### 3 OPEN

Basi noce materia con ripiani Bank con luce led.

Base units in materia walnut with Bank shelves and LED light.

### 4 UP

Boiserie noce materia, ripiani Bank in alluminio e vetro.

Boiserie in materia walnut, Bank shelves in aluminium and glass.

### 5 GAP

Canale attrezzato in alluminio laccato opaco nero a filotop.

Kitchen rack in black mat lacquered aluminium, flush on top.

### 6 TABLE TOP

Tavolo integrato in noce materia.

Integrated top in materia walnut.

### LIVING

### 7 UP

Boiserie laccato nero assoluto opaco, ripiani Bank in alluminio e vetro.

Mat absolut black lacquered boiserie, Bank shelves in aluminium and glass.

### 8 E45

Basi in noce materia.

Base units in materia walnut.

### 9 E45

Basi laccato nero assoluto opaco.

Mat absolut black lacquered base units.

BASI E COLONNE / BASE UNITS AND TALL UNITS BOISERIE E LIVING / BOISERIE AND LIVING LIVING / LIVING



laccato satin nichel  
nickel satin lacquered

noce materia  
materia walnut

laccato nero assoluto opaco  
mat absolute black lacquered

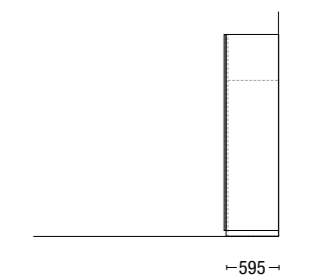
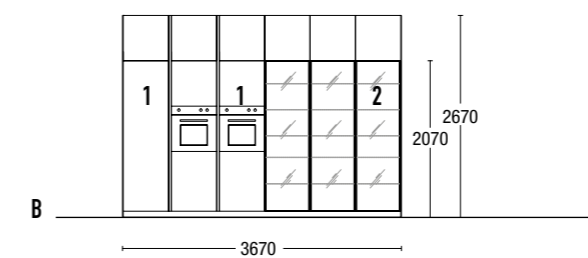
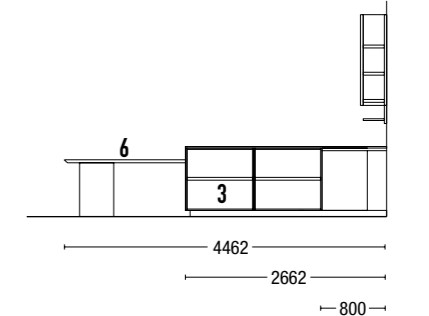
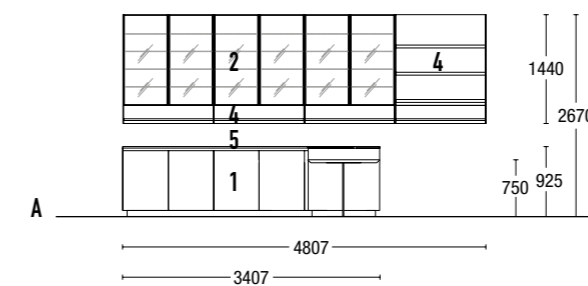

### LIVING

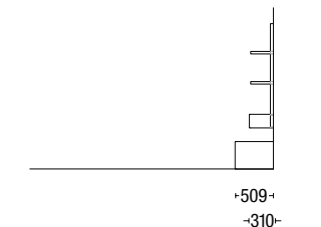
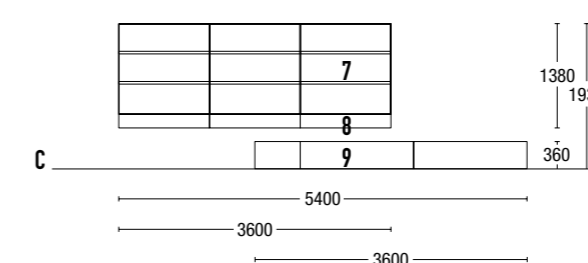

## ANTIS

« Atmosfera calda e accogliente, intensità materica e cromatica, armonia delle forme. La forza progettuale di Antis è sottolineata esteticamente dall'originale profilo maniglia Pro in alluminio laccato.

A warm, cosy atmosphere, beautiful textures and colours, harmonious shapes.

The strong point of Antis design is underlined by the original lacquered aluminium Pro handle profile. »







I meccanismi Kesseböhmer finitura antracite rendono perfettamente accessibile tutto il contenuto dell'armadio: base angolo con meccanismo Le Mans per un miglior sfruttamento degli spazi e ripiani girevoli Turnmotion II con rotazione dei singoli ripiani di 360°. A sinistra, anta con profilo maniglia Pro laccato opaco grigio bromo.

The anthracite Kesseböhmer mechanisms make everything in the cabinet easily accessible: corner base with Le Mans mechanism exploits every bit of space available, Turnmotion II revolving shelves with 360° rotation for each shelf. On the left, door with mat bromo grey lacquered Pro groove profile.









Linee essenziali e progettualità immediata. Pregiate finiture lavorate da abili maestranze per un'estetica purista, tutta da vivere.  
Clean lines and stunning design. Attractive finishes by skilled artisans provide purist good looks.



05  
atmosphere  
**ANTIS**

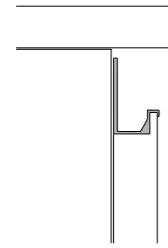

**MULTISYSTEM**

frontali con maniglia PRO alluminio finitura acciaio satinato e laccato opaco

fronts with aluminium PRO handle with satin steel mat lacquered finish.

**1 ANTIS**

Ante basi, colonne e coprifianchi laccato grigio bromo opaco. Maniglia Pro e zoccolo h.8 cm alluminio laccato grigio bromo. Piano top Inclina fenix grigio bromo. Cappa a soffitto.

Doors for base units, tall units and finishing panels in mat bromo grey lacquered. Pro handle and h.8 cm plinth in bromo grey lacquered aluminium. Fenix bromo grey Inclina top. Ceiling hood.

**2 TECA**

Pensili telaio testa di moro e vetro fumé.

Wall units with dark brown frame and fumé glass.

**3 SPACE**

Schienale attrezzato in alluminio nero con schienali eucalipto termotrattato.

Equipped back panel in black aluminium with back panels in thermotreated eucalypt.

**4 SNACK WORKTOP**

Piano snack inclinato su 4 lati in eucalipto termotrattato.

Snack top inclined on 4 sides in thermotreated eucalypt.

**BASI E COLONNE / BASE UNITS AND TALL UNITS SPACE**

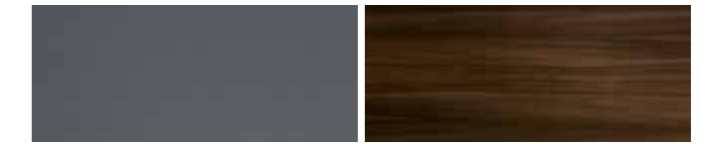

laccato grigio bromo opaco  
mat bromo grey lacquered

eucalipto termotrattato  
thermotreated eucalypt

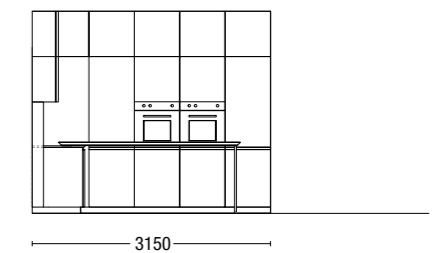
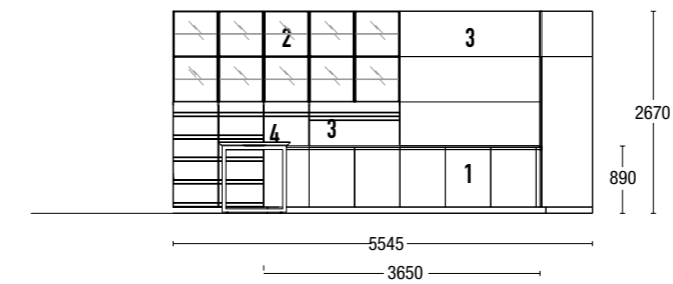
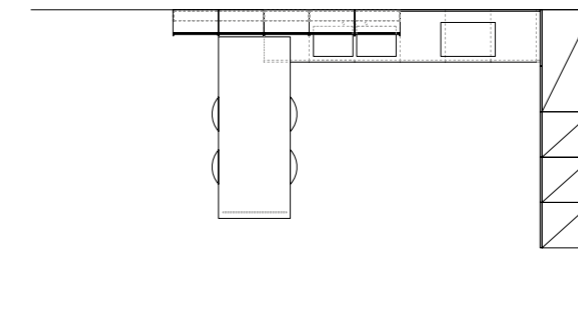

## LAIN

« Una cucina smart ricca di varianti estetiche capace di esprimere con completezza tutte le prestazioni qualitative dei modelli di alta gamma. Un progetto in grado di soddisfare le più svariate esigenze di gusto.

A smart kitchen rich in aesthetic variants that fully express all the quality of performance typical of high range models.

This project can meet the most diverse personal tastes. »



atmosphere 06





Isola con basi a giorno Open, ripiani Bank telaio alluminio e vetro. A sinistra il funzionale profilo maniglia M33 in alluminio inclinato 33° aggiunge un particolare disegno all'anta e crea un'estetica rigorosa e tecnica.

Island with Open unit and Bank shelves with aluminium frame and glass. On the left, the functional M33, a 33° inclined groove profile that gives to the door a special look and creates a precise, technical appearance.





Lain si inserisce nello spazio abitativo caratterizzandone i volumi architettonici attraverso un equilibrato e armonioso dialogo tra pieni e vuoti.  
Lain fits into the home and characterises its architecture by juggling full and empty spaces.





06  
atmosphere  
LAIN

**FILO**

gola con frontali lato maniglia M33 alluminio finitura bianco ottico, acciaio satinato, brill e moka groove profile with M33 handle fronts in optic white finish aluminium, satin steel, brill and mocha

**1 LAIN**

Ante basi e coprifianchi in termostrutturato materico rovere naturale e tecnolamina bianco matt, pensili e colonne tecnolamina bianco matt. Maniglia M33, profilo gola e zoccolo h.8 cm alluminio finitura acciaio inox. Piano laminato ardesia e cappa "sospesa" isola acciaio inox.

**2 OPEN**

Basi termostrutturato materico rovere naturale con ripiani Bank con luce led.

**3 UP**

Boiserie e ripiani termostrutturato materico rovere naturale.

**4 SNACK WORKTOP**

Piano snack sp.4 cm termostrutturato materico rovere naturale inclinato su 4 lati.

Doors for base units and finishing panels in thermostructured textured natural oak and mat white tecnolamina, wall units and tall units in mat white tecnolamina. M33 handle, groove profile and h.8 cm plinth in stainless steel finish aluminium. Ardesia laminate top and "suspended" island hood in stainless steel.

Base units in thermostructured textured natural oak with Bank shelves with LED light.

Boiserie and shelves in thermostructured textured natural oak.

Th.4 cm snack top in thermostructured textured natural oak, inclined on 4 sides.

**BASI, COLONNE E PENSILI**  
BASE UNITS, TALL UNITS AND WALL UNITS

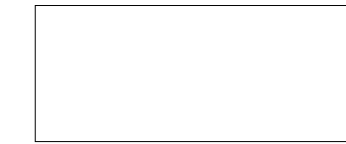

tecnolamina bianco matt  
mat white tecnolamina

**BASI E BOISERIE / BASE UNITS AND BOISERIE**



termostrutturato materico rovere naturale  
thermostructured textured natural oak

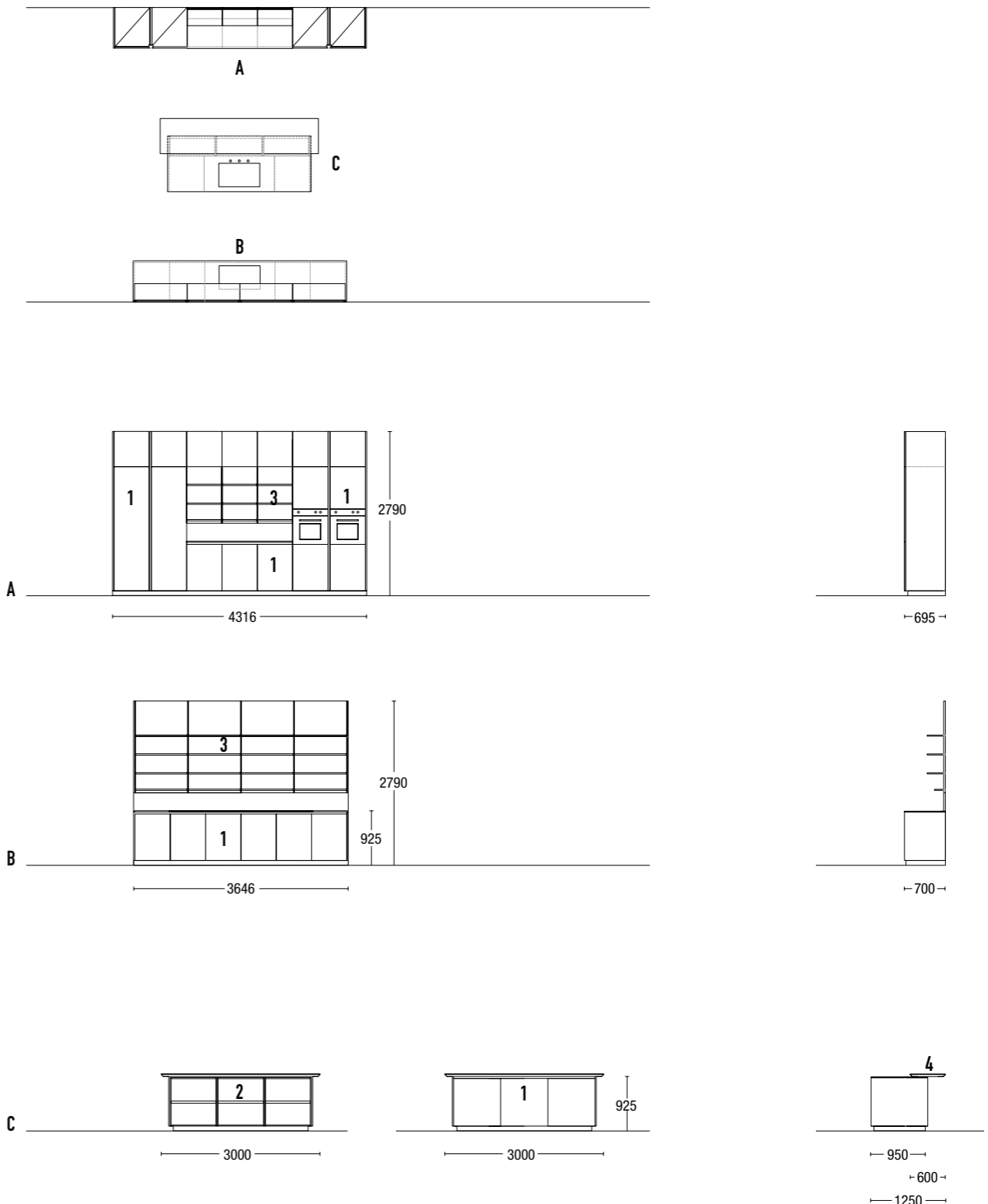



atmosphere  
07





L'innovativo elemento estraibile Kesseböhmer iMove finitura antracite trasforma il pensile in un sistema di stoccaggio ergonomico con più comfort per l'utente. Con un semplice movimento gli oggetti vengono trasportati verso il basso e davanti al pensile. A sinistra, maniglia PRO in alluminio finitura acciaio inox con lunghezza modulare come il frontale.

The innovative anthracite Kesseböhmer iMove pull-out element makes a wall unit into an ergonomic storage system that's comfortable to use. A simple movement takes objects down and places them in front of the wall unit. On the left, stainless steel finish aluminium PRO handle with modular length to conform with the front.







Un'abitazione caratterizzata da ampi tagli architettonici con un progetto cucina che si apre verso volumi spaziali collegati con l'elegante living.  
A home featuring grand architectural style with a kitchen project that opens out to connect with the elegant living room.







# 07 atmosphere LAIN

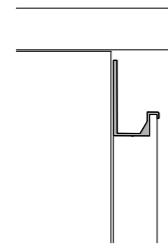

## MULTISYSTEM

frontali con maniglia PRO alluminio finitura acciaio satinato e laccato opaco  
fronts with PRO handle in brushed steel finish aluminium and mat lacquered

### 1 LAIN

Ante basi, colonne, pensili e coprifianchi ecolaccato perla. Maniglia Pro alluminio finitura acciaio inox. Zoccolo h.8 cm alluminio laccato perla. Piano top laminato bordo unicolor perla sp.20 mm con cappa integrata su piano cottura.

### 2 FRAME

Colonne telaio titanio e vetro extralight con cornice laccato perla opaco.

### 3 HORIZON

Boiserie e mensole termostrutturato lignum dark, profili di chiusura neri.

### 4 TABLE TOP

Tavolo integrato termostrutturato lignum dark.

### LIVING

### 5 HORIZON

Boiserie e mensole termostrutturato lignum dark, profili di chiusura neri.

### 6 E90

Basi sospese in ecolaccato perla.

### 7 SMART

Sistema pensili ecolaccato perla e bianco ottico.

Doors for base units, tall units, wall units and finishing panels in pearl ecolaccato. Pro stainless steel finish aluminium handle. h.8 cm pearl lacquered aluminium plinth. Th.20 mm laminate top with pearl unicolor edge and hob integrated hood.

Tall unit with chassis in titanium and extralight glass with mat pearl lacquered frame.

Boiserie and shelves in thermostructured lignum dark, black closing profiles.

Integrated table in thermostructured lignum dark.

Boiserie and shelves in thermostructured lignum dark, black closing profiles.

Ecolaccato pearl suspended base units.

Wall unit system in ecolaccato pearl and optic white.

#### BASI, COLONNE, PENSILI E LIVING

BASE UNITS, TALL UNITS, WALL UNITS AND LIVING

LIVING / LIVING

BOISERIE E LIVING / BOISERIE AND LIVING

COLONNE / TALL UNITS



ecolaccato perla  
pearl ecolaccato

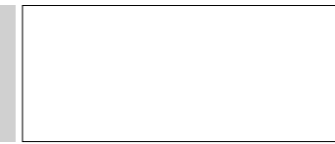

ecolaccato bianco ottico  
optic white ecolaccato



thermostrutturato lignum dark  
thermostructured lignum dark



vetro extrachiaro con cornice laccato perla opaco  
extralight glass with pearl mat lacquered frame

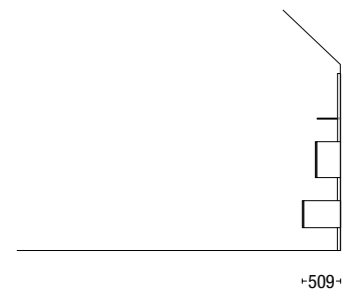
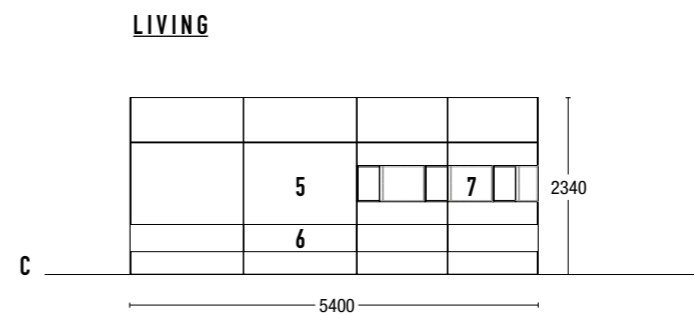
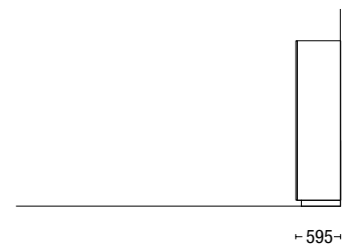
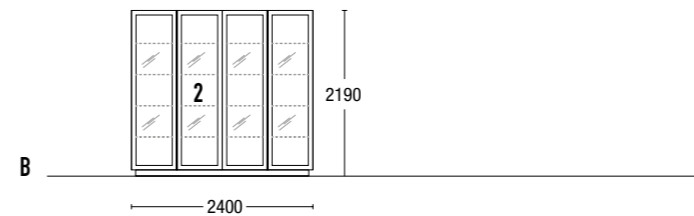
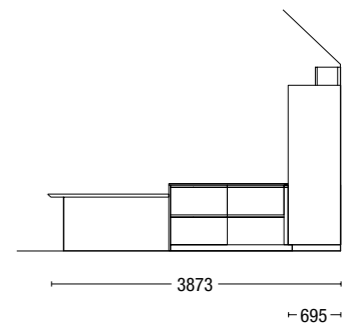
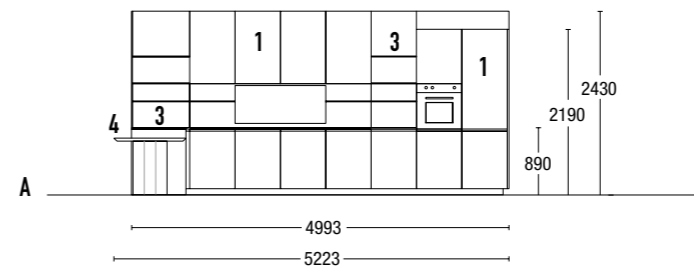
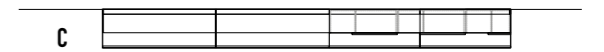
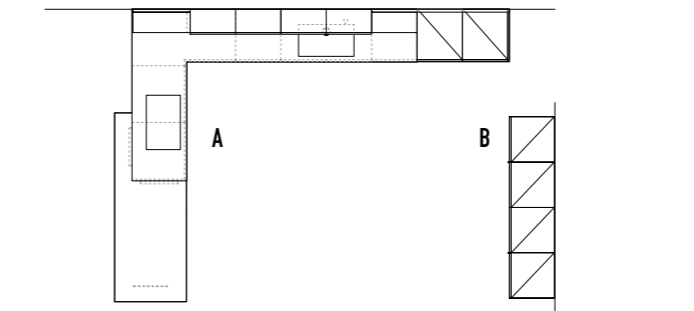

## FILÒ

« Linguaggi della tradizione rivisitati  
in chiave contemporanea.  
Il nome, ripreso da un progetto  
degli anni '90, evoca momenti  
di vita familiare unici e intensi.

Tradition revisited in a  
contemporary key. The name,  
taken from a 1990s project,  
evokes unique times  
of intense family life. »









Sofisticato e suggestivo gioco di rimandi tra passato e presente, tradizione e innovazione. Completano il progetto elementi e sistemi innovativi e funzionali.

A sophisticated game, play with elements of the past and present, tradition and innovation.

The project includes innovative, functional elements and systems.





Particolare effetto scenico tra la pregiata finitura Fusion lavorata artigianalmente e l'elegante anta telaio. Due ante accostate formano un montante di 9 cm, uguale ai traversi orizzontali, originando un rigoroso gioco geometrico. Completa il progetto il piano snack Moove con scorrimento in diagonale.

A special effect is created by the attractive Fusion artisan finish and the elegant framed door. Two side by side doors create a 9 cm upright that repeats the cross pieces to produce a precise geometrical appearance. The project is completed with a Moove snack top that slides diagonally.







# 08 atmosphere FILÒ

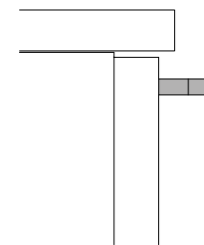

## MULTISYSTEM

frontali con  
maniglia Tag  
fronts with  
Tag handle

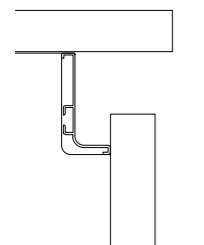

## FILÒ

gola con  
frontali dritti  
groove profile  
with straight fronts

### 1 FILÒ

Ante basi, colonne e coprifianchi laccato fusion ossidato e vetro fumé serigrafato. Maniglia Tag laccato nero assoluto opaco. Profilo gola e zoccolo h.8 cm alluminio laccato nero assoluto opaco. Piano top granito nero assoluto finitura tranchè sp.20 mm.

Doors for base units, tall unit and finishing panel in oxidized fusion lacquered and screen-printed fumé glass. Mat absolut black lacquered Tag handle. Groove profile and plinth h.8 cm mat absolut black lacquered aluminium. Top in th. 20 mm tranchè finish absolut black granite.

### 2 UP

Boiserie eucalipto termotrattato.

Boiserie in thermotreated eucalypt.

### 3 GAP

Canale attrezzato in alluminio laccato opaco nero a filotop con cappa integrata.

Flush on top mat black lacquered aluminium kitchen rack, with integrated hood.

### 4 CABINET

Colonna con anta rientrante laccato fusion ossidato con attrezzatura interna.

Tall unit with oxidized fusion lacquered recessed door with interior fittings.

### 5 MOOVE

Piano snack eucalipto termotrattato.

Snack top in thermotreated eucalypt.

BASI E COLONNE / BASE UNITS AND TALL UNITS BOISERIE / BOISERIE



laccato fusion ossidato  
oxidized fusion lacquered



eucalipto termotrattato  
thermotreated eucalypt

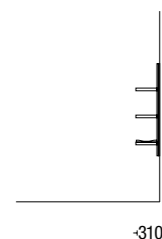
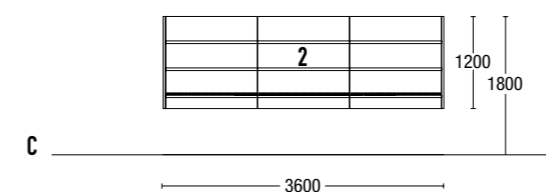
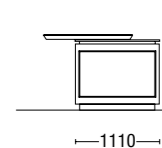
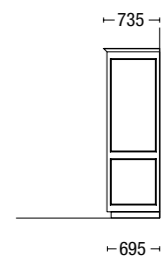
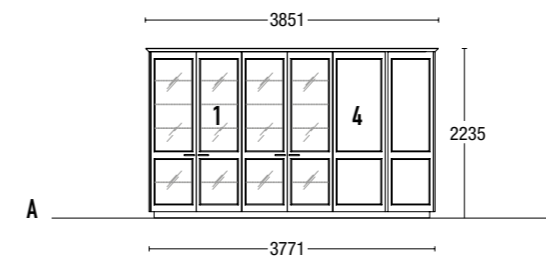
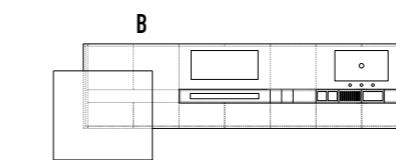
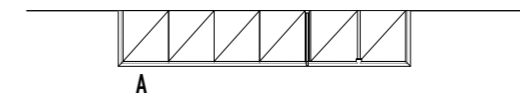



atmosphere 09



Ritratto di cucina di classe per una soluzione progettuale perfettamente integrata in una dimora d'epoca.  
 Portrait of a classy kitchen that fits perfectly into an historic house.







atmosphere  
**FILÒ**

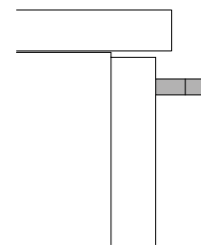

**MULTISYSTEM**

frontali con  
maniglia Tag  
fronts with  
Tag handle

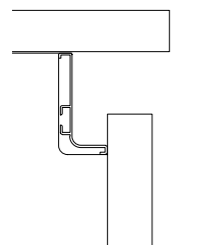

**FILÒ**

gola con  
frontali dritti  
groove profile  
with straight fronts

**BASI, COLONNE E PENSILI**  
BASE UNITS, TALL UNITS AND WALL UNITS

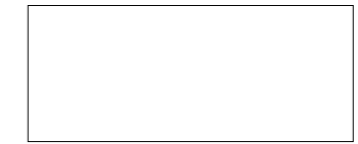

laccato bianco ottico opaco  
mat optic white lacquered

**1 FILÒ**

Ante basi, colonne e coprifianchi laccato bianco ottico opaco. Pensili laccato bianco ottico opaco e vetro fumé serigrafato. Profilo gola e zoccolo h.8 cm alluminio laccato bianco ottico opaco. Maniglia Tag acciaio satinato. Piano top gres porcellanato Laminam orobico grigio sp.12 mm con cappa a soffitto.

Doors for base units, tall units and finishing panels in mat optic white lacquered. Wall units in mat optic white lacquered and screen-printed fumé glass. Groove profile and plinth h.8 cm in mat optic white lacquered aluminium. Tag handle in brushed steel. Th.12 mm top in porcelain gres Laminam orobic grey with ceiling hood.

**2 OPEN**

Base laccato bianco ottico opaco e ripiani Bank vetro fumé.

Mat optic white lacquered base unit and Bank fumé glass shelves.

**3 UP**

Boiserie laccato bianco ottico opaco e ripiani Bank vetro fumé e luce led.

Mat optic white lacquered boiserie and Bank fumé glass shelves with LED light.

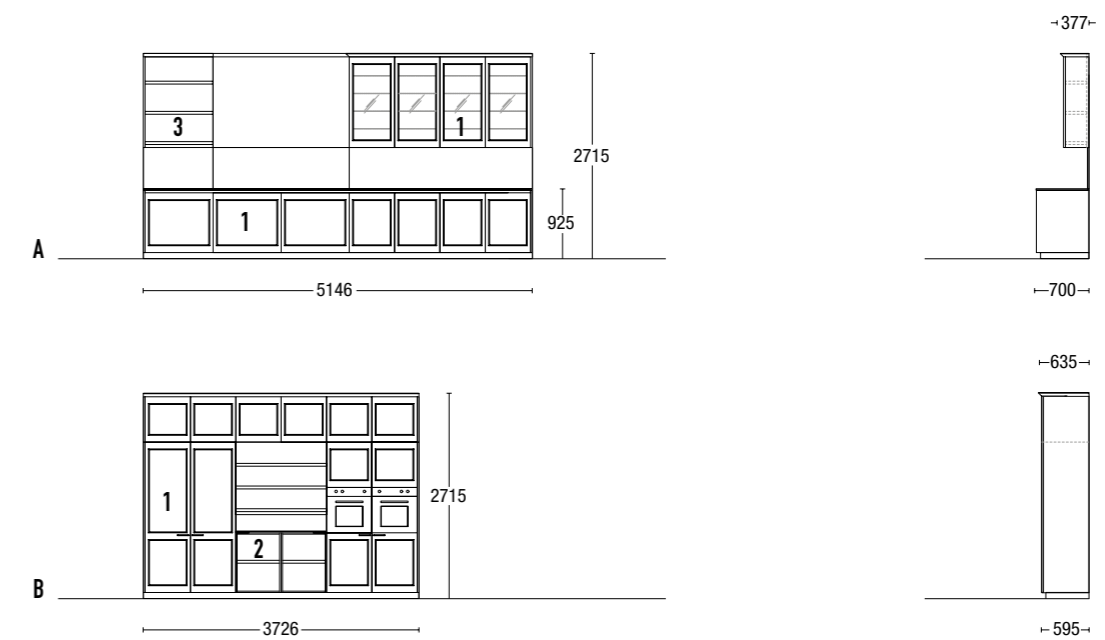
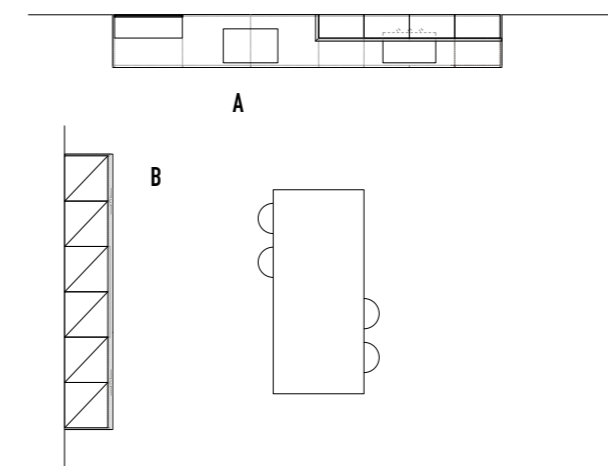



atmosphere  
10







Spazi domestici inusuali diventano architetture straordinarie per una cucina senza tempo, protagonista scenografica dei grandi volumi.  
Unusual domestic areas become stunning architecture for this large, timeless kitchen.

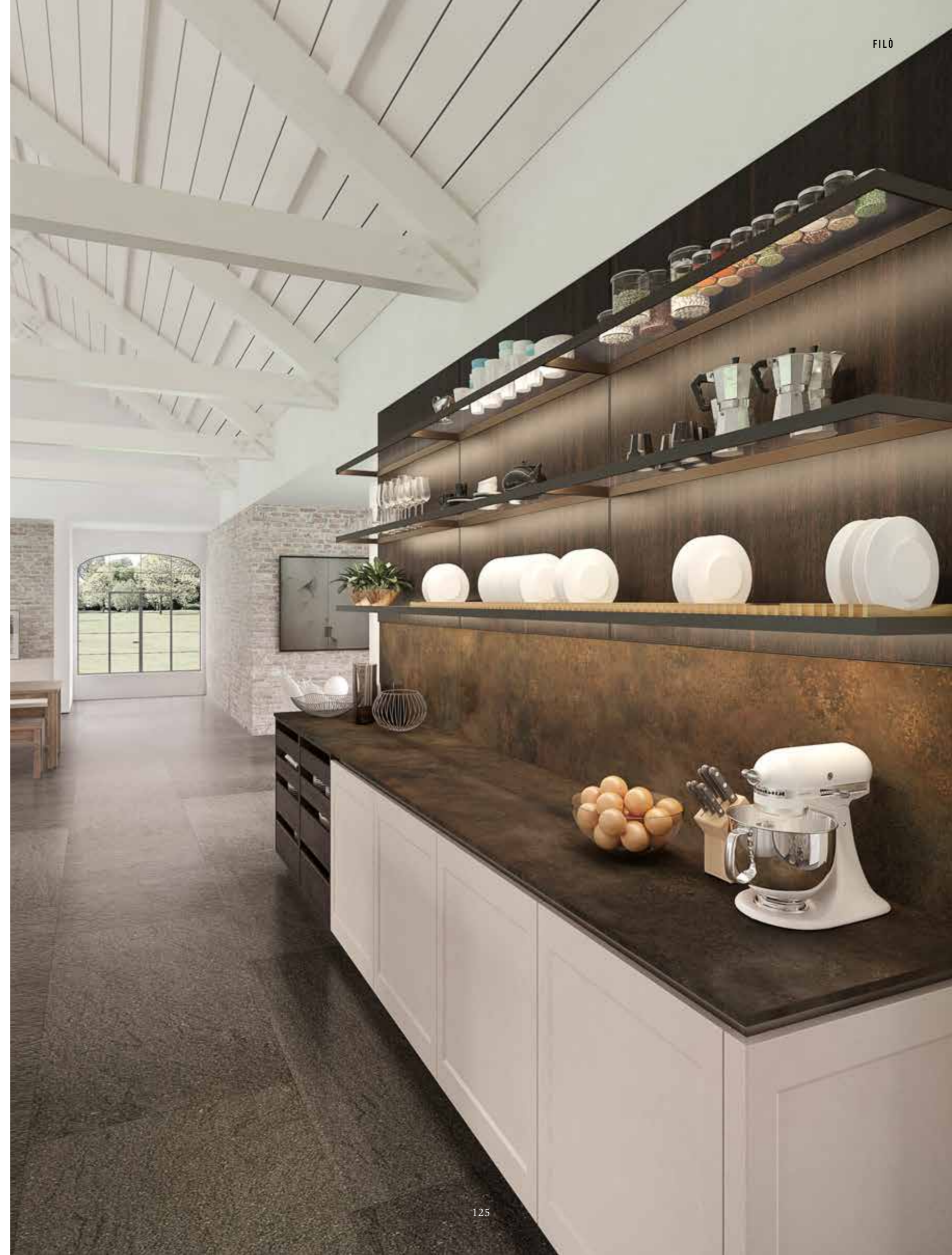





# 10 atmosphere FILÒ

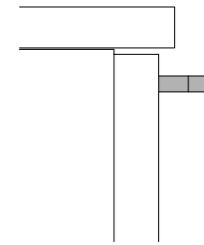

## MULTISYSTEM

frontali con maniglia Tag  
fronts with Tag handle

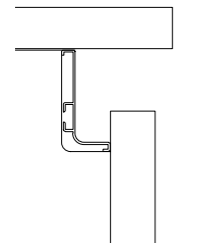

## FILÒ

gola con frontali dritti  
groove profile with straight fronts

### 1 FILÒ

Ante basi e coprifianchi laccato cashmere opaco, colonne laccato cashmere opaco e vetro fumé serigrafato. Profilo gola alluminio laccato opaco cashmere e zoccolo h.8 cm finitura titanio. Maniglia Tag laccato nero assoluto opaco. Piano top gres porcellanato Laminam ossido bruno sp.12 mm.

Doors for base units and finishing panels in mat cashmere lacquered, tall units in mat cashmere lacquered and screen-printed fumé glass. Mat cashmere lacquered aluminium groove profile and h.8 cm plinth with titanium finish. Mat absolut black lacquered Tag handle. Th.12 mm top in porcelain gres Laminam dark oxide.

### 2 OPEN

Base eucalipto termotrattato e ripiani Bank vetro fumé, base con cassetti eucalipto termotrattato.

Base unit in thermotreated eucalypt and Bank fumé glass shelves, thermotreated eucalypt base unit with drawers.

### 3 UP

Boiserie eucalipto termotrattato e ripiani Bank vetro fumé e luce led.

Boiserie in thermotreated eucalypt and Bank fumé glass shelves with LED light.

### 4 GAP

Canale attrezzato in alluminio laccato opaco nero a filotop con cappa integrata.

Flush on top mat black lacquered aluminium kitchen rack with integrated hood.

### 5 CABINET

Colonna laccato cashmere opaco con attrezzatura interna.

Mat cashmere lacquered tall unit with interior fittings.

### 6 SNACK WORKTOP

Piano snack eucalipto termotrattato.

Snack top in thermotreated eucalypt.

## BASI E COLONNE / BASE UNITS AND TALL UNITS BOISERIE / BOISERIE



laccato cashmere opaco  
mat cashmere lacquered

eucalipto termotrattato  
thermotreated eucalypt

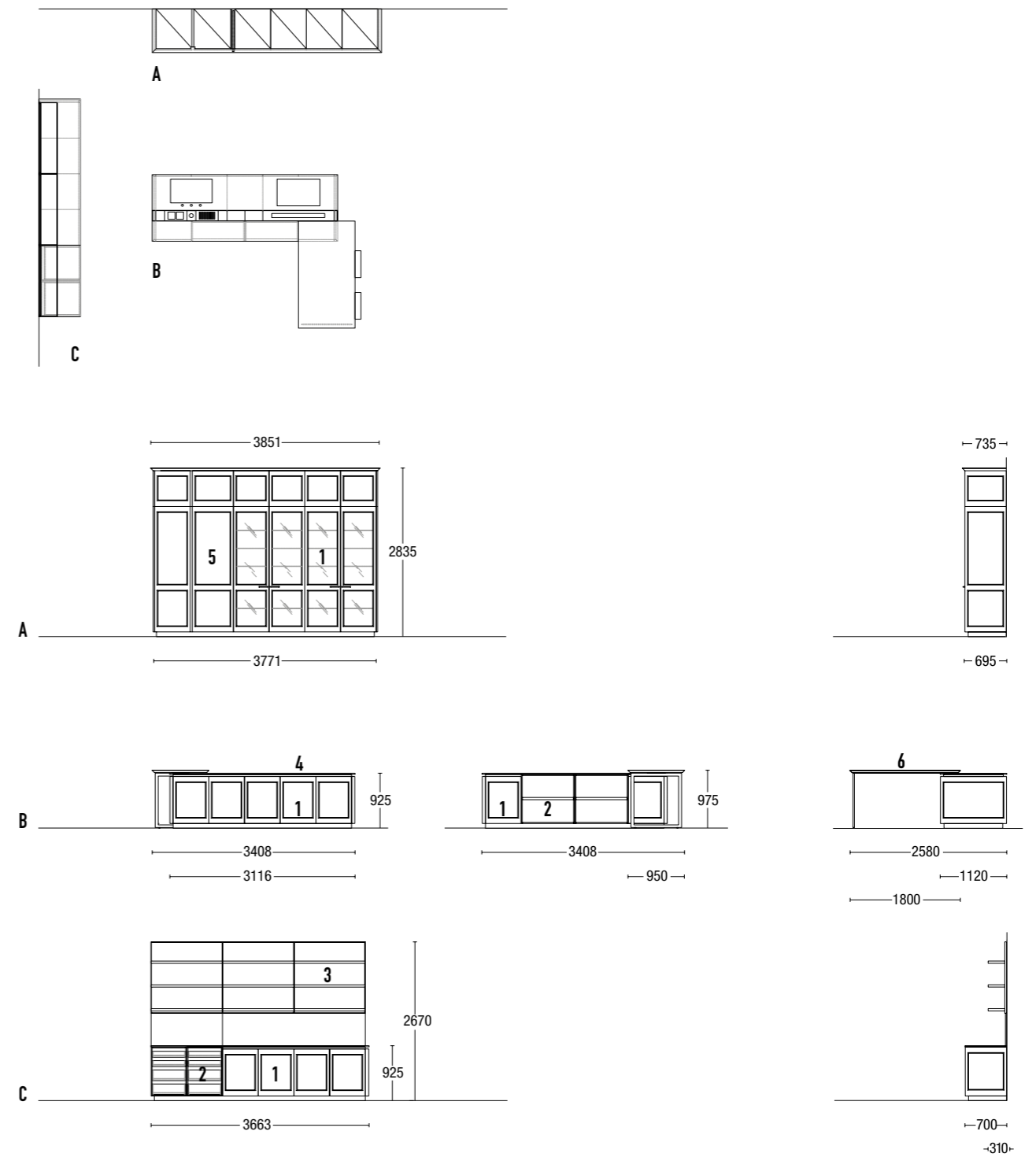

## KUBIC

« Tecnologia esclusiva brevettata per l'anta in vetro temprato, 100% riciclabile ed idrorepellente, progettata per essere leggera e robusta; retro in alluminio laccato coordinato nel colore vetro. »

Exclusive patented technology for this toughened glass door, 100% recyclable and waterproof, designed to be lightweight and robust; lacquered aluminium back panel coordinated with the colour of the glass. »



atmosphere







Assoluta sicurezza con l'anta vetro temprato sp.3 mm, taglio a 33° lato maniglia. Nel dettaglio basi sospese attrezzate con luce led.

Absolute safety with this th.3 mm toughened glass door featuring a 33° cut on the handle side. The detail shows suspended base units with LED lights.







Le colonne diventano quinta scenografica di raccordo tra l'area cucina e il living. I pensili, completi di sistema a giorno E45, creano un raffinato gioco grafico.

Tall units create a spectacular wing that connects the kitchen and living room areas. The wall units come with the E45 open system and produce a refined graphic effect.

11  
atmosphere  
KUBIC

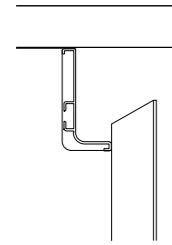

**FIL033**

gola con frontali  
lato maniglia  
inclinato 33°  
groove profile  
with 33° inclined  
handle fronts

**1 KUBIC**

Ante basi, colonne e coprifianchi  
alluminio e vetro ardesia opaco.  
Profilo gola alluminio laccato ardesia  
opaco, zoccolo h.8 cm alluminio  
laccato ardesia opaco. Piano  
in quarzo Raven sand sp.20 mm.  
Cappa integrata su pensile.

Doors for base units, tall units and  
finishing panels in aluminium and  
mat ardesia glass. Mat ardesia lacquered  
aluminium groove profile, mat ardesia  
lacquered aluminium h.8 cm plinth.  
Th.20 mm top in Raven sand quartz.  
Hood integrated in the wall unit.

**2 ANTIS**

Pensili rovere materia carbone.

Wall units in coal materia oak.

**3 SPACE**

Schienale attrezzato in alluminio  
finitura nero e schienale rovere  
materia carbone, rivestimento  
acciaio inox sulla zona cottura.

Black finish aluminium equipped  
back panel and back panel  
in coal materia oak, stainless  
steel clad cooking hob area.

**4 E45**

Elementi contenitori a giorno  
rovere materia carbone.

Open storage units in  
coal materia oak.

BASI E COLONNE / BASE UNITS AND TALL UNITS    PENSILI E SPACE / WALL UNIT AND SPACE



vetro ardesia opaco  
mat ardesia glass

rovere materia carbone  
coal materia oak

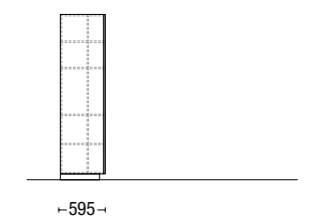
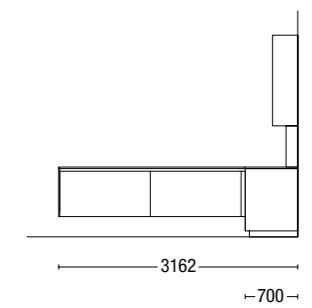
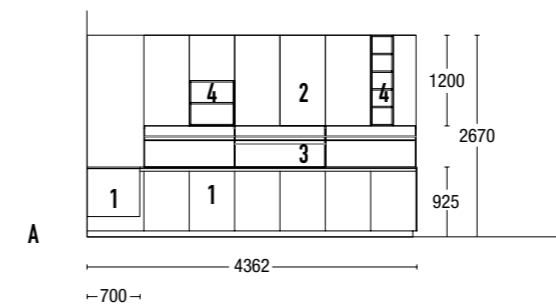
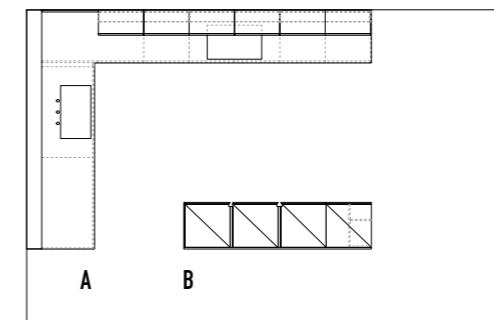



atmosphere

12

## ASSIM

« Un frontale unico e grafico con la maniglia asimmetrica in due lunghezze, ricavata nello spessore dell'anta: segno forte e caratterizzante del progetto.

A unique, graphic front with two-length asymmetrical handle carved out of the door is the distinguishing feature of this project. »





Volumi geometrici, massima semplicità per una soluzione che vede protagonista il sistema Flexy ante complanari su basi e colonne.  
 Geometry and maximum simplicity for this solution featuring the Flexy coplanar door system on base units and tall units.





Una grande penisola per un concetto compositivo che articola e organizza lo spazio domestico rendendo il progetto cucina centro vitale della casa. Nel dettaglio, ripiano basi con originale profilo anticaduta.

A large peninsula articulates and organises space to make the kitchen the vital hub of the home. The detail shows a base unit shelf with its original non-tip edging.





Sistema Flexy ante complanari aperte: vano forni e cassetti Cube grafite. Tutto è organizzato e nascosto dalle grandi ante, il risultato è una cucina sempre più raffinata e rigorosa.

Flexy system open coplanar doors: oven space and Cube graphite drawers. Everything is organized and concealed behind large doors to give your kitchen a stunning, refined look.

# 12 atmosphere ASSIM

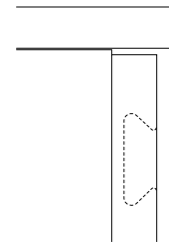

## MULTISYSTEM

frontali con  
maniglia integrata  
fronts with  
integrated handle

### 1 ASSIM

Ante basi, colonne e coprifianchi  
laccato bianco ottico lucido.  
Zoccolo h.8 cm alluminio laccato  
bianco ottico. Piano in pietra  
acrilica bianco assoluto sp. 20 mm.  
Cappa "sospesa" isola bianco.

Doors for base units, tall units and  
finishing panels in glossy optic white  
lacquered. Optic white lacquered  
aluminium h.8 cm plinth. Th.20 mm  
top in absolut white acrylic stone.  
White "suspended" island hood.

### 2 FRAME

Pensili telaio nero assoluto e  
vetro fumé con cornice laccato  
nero assoluto opaco.

Wall units with chassis in absolut  
black and fumé glass with mat  
absolut black lacquered frame.

### 3 UNOEDUE

Pensili a giorno laccato nero  
assoluto lucido.

Glossy absolut black lacquered  
open wall units.

BASI E COLONNE / BASE UNITS AND TALL UNITS    PENSILI / WALL UNIT

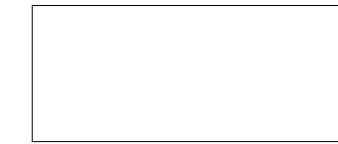

laccato bianco ottico lucido  
glossy optic white lacquered

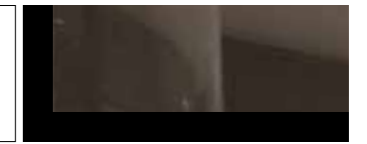

vetro fumé con cornice laccato nero assoluto opaco  
fumé glass with mat absolut black lacquered frame

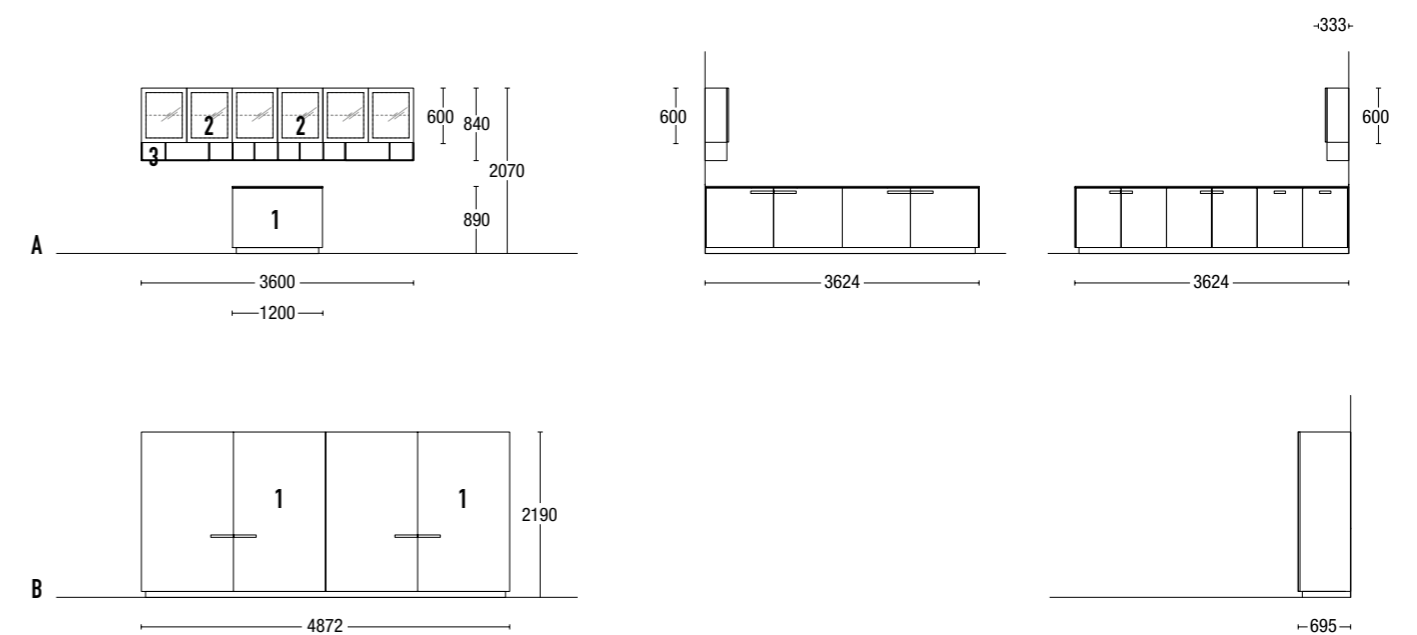
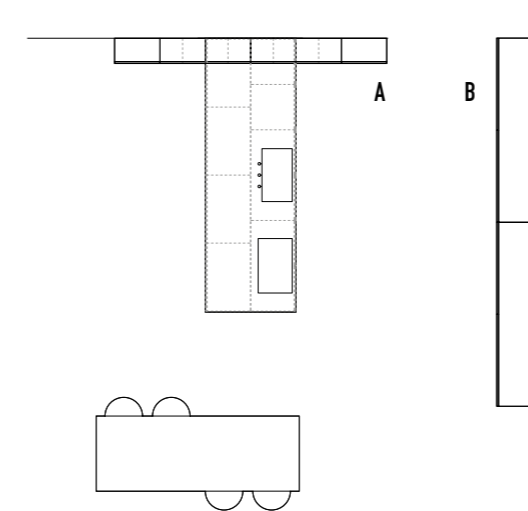





atmosphere  
13

## FREE STEEL

« Una scelta da chef, massima espressione tecnologica, di solidità e leggerezza estetica: acciaio inox AISI 304 satinato antimpronta, 100% riciclabile, assicura doti di resistenza uniche.

The chef's choice, great technology, robustness and attractive aesthetics: 100% recyclable, fingerprint proof AISI 304 satin stainless steel provides unique strength. »





A sinistra, anta acciaio inox AISI 304 sul frontale e sui bordi, alluminio retro anta. Colonna attrezzata con meccanismo estraibile Lavidò finitura cromo lucido.  
On the left, door with AISI 304 stainless steel front and edges, aluminium back. Equipped tall unit with Lavidò glossy chrome finish pull-out mechanism.





Personalità unica per la cucina dell'appartamento metropolitano con anta acciaio inox, maniglia su colonne e gola dalla linea pulita ed ergonomica per le basi.  
Unique personality for this city flat kitchen featuring stainless steel doors, handles on tall units and uncluttered, ergonomic groove profiles on the base units.



# 13

atmosphere

## FREE STEEL

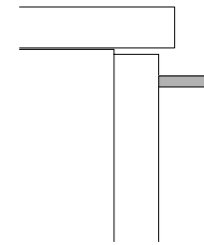

### MULTISYSTEM

frontali con maniglia Regula  
fronts with Regula handle

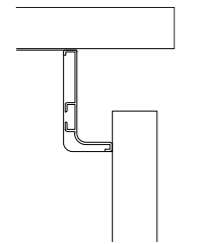

### FILO

gola con frontali dritti  
groove profile with straight fronts



gola con frontali dritti  
groove profile with straight fronts



gola con frontali dritti  
groove profile with straight fronts

### 1 FREE STEEL

Ante basi, colonne e coprifianchi acciaio inox satinato antimpronta. Maniglia Regula cromo lucido. Profilo gola e zoccolo h.8 cm alluminio finitura acciaio inox. Piano in acciaio inox effetto pieno sp. 8 mm. Cappa a soffitto.

Fingerprint proof brushed stainless steel doors for base units, tall units and finishing panels. Glossy chrome Regula handle. Groove profile and h.8 cm plinth in stainless steel finish aluminium. Th.8 mm top in full effect stainless steel. Ceiling hood.

### 2 ANTIS

Pensili laccato nero assoluto opaco.

Wall units in mat absolut black lacquered.

### 3 HORIZON

Boiserie e accessori con magnete in laccato nero assoluto opaco e profili di testa alluminio anodizzato nero.

Mat absolut black lacquered boiserie with magnetised accessories, front profiles in black anodized aluminium.

### 4 THIN

Tavolo snack laccato nero assoluto opaco.

Mat absolut black lacquered snack table.

BASI E COLONNE / BASE UNITS AND TALL UNITS PENSILI E BOISERIE / WALL UNITS AND BOISERIE



acciaio inox satinato antimpronta  
fingerprint proof brushed stainless steel



laccato nero assoluto opaco  
mat absolute black lacquered

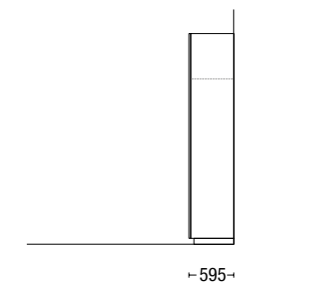
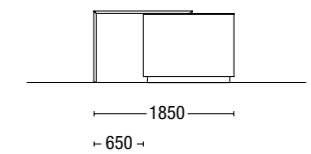
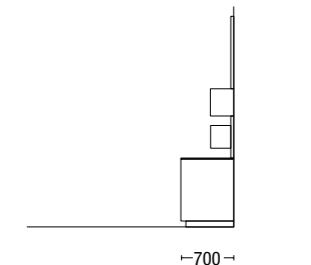
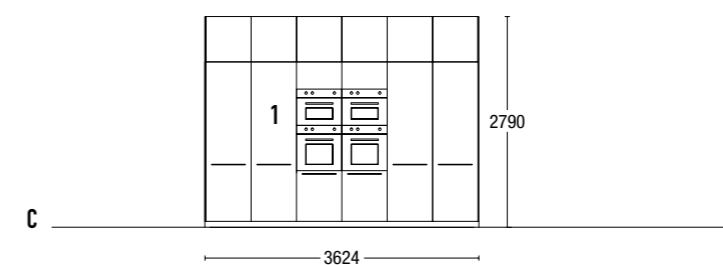
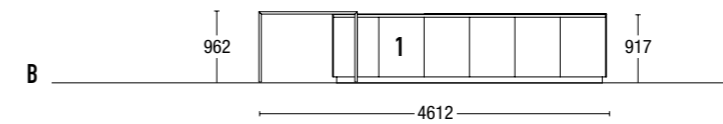
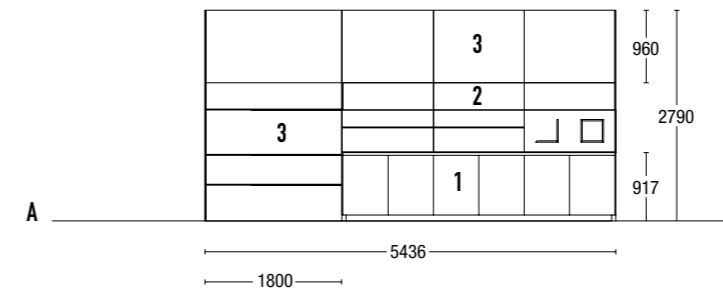
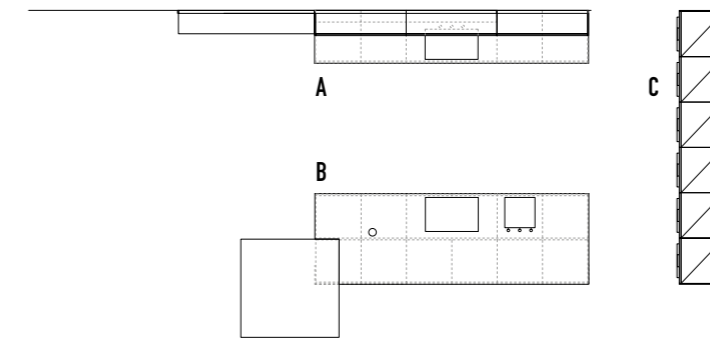

# KITCHEN SYSTEM

Walter Gropius, esterno della Bauhaus (laboratori), 1925-1926, Dessau.  
L'edificio progettato da Gropius con la collaborazione dei maestri e degli allievi della scuola, è uno dei massimi capolavori dell'architettura moderna. L'esperienza della Bauhaus, iniziata nel 1919 e conclusasi nel 1933, ha rappresentato un alto e significativo momento di sviluppo culturale per diverse generazioni di artisti e progettisti.

Walter Gropius, Bauhaus exterior (laboratories), 1925-1926, Dessau.  
The building designed by Gropius together with the school teachers and students is one of the greatest masterpieces of modern architecture. The Bauhaus experience started in 1919 and ended in 1933 and represented a significant period of cultural development for several generations of artists and designers.



**FRAME**





## FRAME

### ante vetro glass doors

Anta vetro con struttura alluminio finitura titanio e nero assoluto e vetro temprato trasparente extrachiaro e fumé con cornice laccata in un'ampia gamma di colori. L'anta vetro Frame su pensili è senza maniglia.

Glass doors with absolut black titanium finish aluminium frame and extralight and fumé transparent toughened glass with frame lacquered in a wide choice of colours. The Frame glass door on wall units is without a handle.





## FRAME

ante vetro  
glass doors

L'anta vetro Frame su colonne presenta un'elegante maniglia in alluminio sul bordo verticale, a tutta altezza. Il dettaglio esprime la qualità tecnica ed estetica della maniglia.

The Frame glass door on tall units has an elegant, full height aluminium handle on the vertical edge. The detail shows the aesthetic and technical quality of the handle.





**TECA**



## TECA

### ante vetro glass doors

Rigorosa e raffinata, con 2 cerniere a scomparsa, calamita integrata nel telaio per chiusura e il vetro temprato sp.4 mm fumé o extrachiaro, riduce al minimo la presenza del telaio, disponibile in due finiture, testa di moro e titanio.

Stern and refined, the 2 concealed hinges, closing magnet incorporated in the frame and th.4 mm fumé or extralight toughened glass reduce the impact of the frame to a minimum. Available in two finishes, dark brown or titanium.





FILÒ



## FILÒ

### ante vetro glass doors

L'anta vetro Filò presenta un elegante decoro a losanghe serigrafato che unisce il passato al futuro. Il gradevole impatto visivo si esalta con l'armonico coordinamento alla dinamica anta telaio Filò. Il vetro temperato è proposto nelle varianti extralight, fumé e fumé serigrafato.

The Filò glass door features an elegant, screen-printed diamond pattern that takes the past into the future. The pleasant effect is exalted by well-balanced coordination with the Filò dynamic framed door. The toughened glass comes extralight, fumé or screen-printed fumé.





OPEN



## OPEN

### basi a giorno open base units

Pratico e innovativo sistema basi a giorno disponibile sia con ripiani Bank, struttura alluminio e piano vetro, sia con ripiani sp.20 mm in un'ampia gamma di materiali. Il sistema Open si completa di funzionali ed ecosostenibili luci LED.

The open base unit system is practical and innovative and comes with Bank shelves, aluminium carcass and glass shelf or th.20 mm shelves in a wide range of materials. Functional, ecosustainable LED lights complete the Open system.





## OPEN

### basi a giorno open base units

Il sistema basi a giorno Open propone la versione con ampi cassetti e cestoni nella materica finitura eucalipto termotrattato, attrezzati con funzionali accessori in legno.

The Open base unit system includes a version with large drawers and deep drawers in thermotreated eucalypt textured finish, equipped with practical wooden accessories.



# HORIZON



## HORIZON

### sistema boiserie cremagliera orizzontale boiserie system on horizontal rail

Sistema boiserie a cremagliera orizzontale con elemento scorrevole e diversi mood materici. Prevede profili e tappi di chiusura, sistema antiganciamento mensola, lavorazioni su misura e grande portata fino a 16 kg.

Boiserie system on horizontal rail with sliding element and a choice of several textures. The system includes profiles and closing caps, a non-tip shelf system, customised measurements and high capacity up to 16 kg.





## **HORIZON**

accessori magnetici  
magnetised accessories

Il pannello della boiserie Horizon, in acciaio inox satinato sopra base, consente il libero posizionamento di accessori dotati di magneti.

The stand-on Horizon boiserie panel in satin stainless steel can be used to hold magnetised accessories.

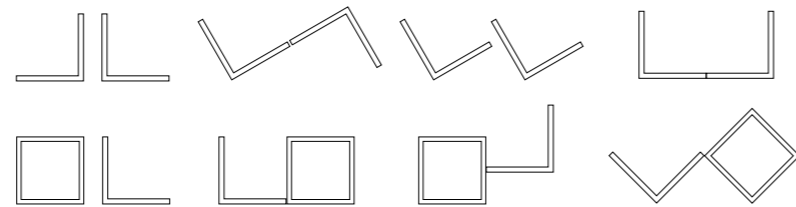



UP



## UP

### sistema boiserie cremagliera verticale boiserie system on vertical rail

Sistema boiserie con cremagliera verticale in alluminio elettrificata. I ripiani coordinati con le finiture dei pannelli e ripiani Bank alluminio e vetro, privi di cavo elettrico, si possono spostare a piacere poiché la luce LED si alimenta automaticamente al contatto del ripiano con il profilo cremagliera. Il ripiano Bank si completa di tre funzionali accessori: portapiatti, portabottiglie e portabicchieri.

Boiserie system on an electrified aluminium vertical rail. The shelves coordinated with the finishes on the panel and Bank aluminium and glass shelf come without electrical wiring and can be moved as wished because the LED light is automatically powered when the shelf is in contact with the rail. The Bank shelf has three practical accessories: plate rack, bottle rack and drinking glass holder.

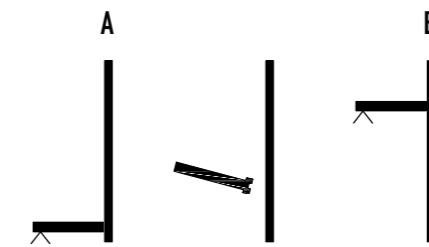

I ripiani, spostabili a piacere lungo la cremagliera con passo di 4 cm, sono privi di cavo elettrico e la luce LED si alimenta automaticamente al contatto del ripiano con il profilo cremagliera elettrificata.  
The shelves can be moved to requirements along the rail with 4 cm pitch. They come without electrical wiring and the LED light is automatically powered when the shelf is in contact with the electrified rail.





SPACE







## SPACE

### schienale attrezzato equipped back panel

Schienale attrezzato con struttura in alluminio nelle finiture titanio e nero e schienale opzionale coordinato ai frontali. Raccordo tra base e pensile, regolabile in altezza, e ampia gamma di accessori abbinabili.

Equipped back panel with titanium and black aluminium structure, optional back panel coordinated with the fronts. Height adjustable connection between base units and wall units and a wide range of coordinating accessories.



GAP

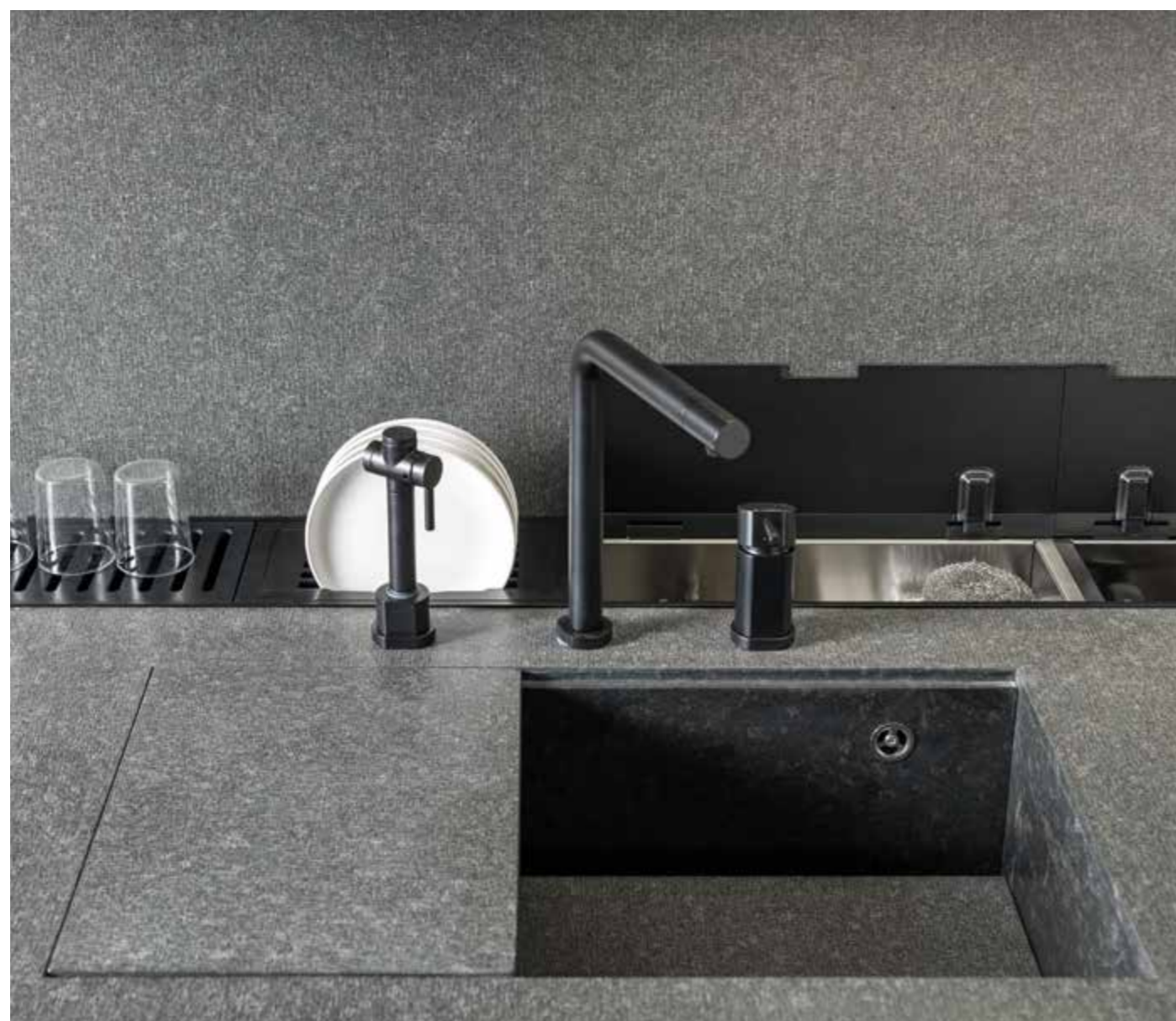

## GAP

### canale attrezzato kitchen rack

Canale attrezzato in alluminio a filotop per piani di lavoro, con vasta gamma di accessori inseribili a piacere. Disponibile nelle finiture laccato opaco bianco o nero.

Aluminium kitchen rack flush on top for worktops, with a wide range of accessories. Available in black or white mat lacquered finishes.





# CABINET



L.138 cm

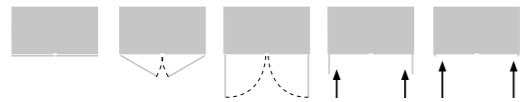

## Cabinet Kitchen unità operativa a scomparsa concealed work station

Cabinet, sistema operativo a scomparsa predisposto per l'inserimento di basi e di pensili di serie.

Cabinet is a concealed work station prepared to take standard base units and wall units.



L. 138 cm

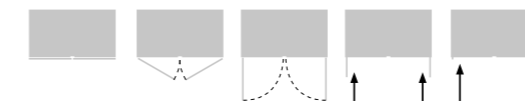

### Cabinet Dispensa unità operativa a scomparsa concealed work station

Colonna con attrezzatura interna 2 cestoni e 2 cassetti, piano estraibile in acciaio inox, prese elettriche integrate nel retro carter in acciaio inox, schienale in vetro (optional), ripiani Bank in alluminio e vetro, luce LED Malindi sul cappello con micro interruttore infrarosso.

Tall storage unit containing 2 deep drawers and 2 drawers, stainless steel pull-out top, plugs incorporated into the stainless steel back cover, glass back panel (optional), aluminium and glass Bank shelves, Malindi LED light on top cover with infrared micro switch.





### Cabinet singolo e Cabinet Eldom single Cabinet and Eldom Cabinet

Sistemi evoluti pensati per il massimo sfruttamento dello spazio e per un utilizzo semplificato. Cabinet anta rientrante sul fianco del mobile per una totale accessibilità.

Avant garde systems designed for full use of space and simplicity in use. Recessed Cabinet door on the side of the unit for total accessibility.

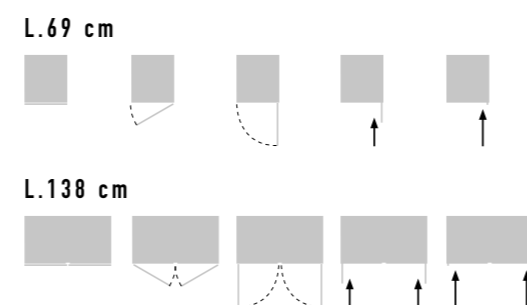



# SMART





## SMART

sistema living contenitori chiusi e a giorno  
living system of closed and open storage units

Sistema con elementi pensili comodo e funzionale, progettato con un'estetica minimale e rigorosa che concede una combinazione di pieni e di vuoti e di effetti cromatici. Elegante mensola in vetro all'interno dei vani chiusi.

System with convenient, functional wall units featuring minimal design that provides a combination of full and empty spaces and colour effects. An elegant glass shelf is placed inside the closed units.

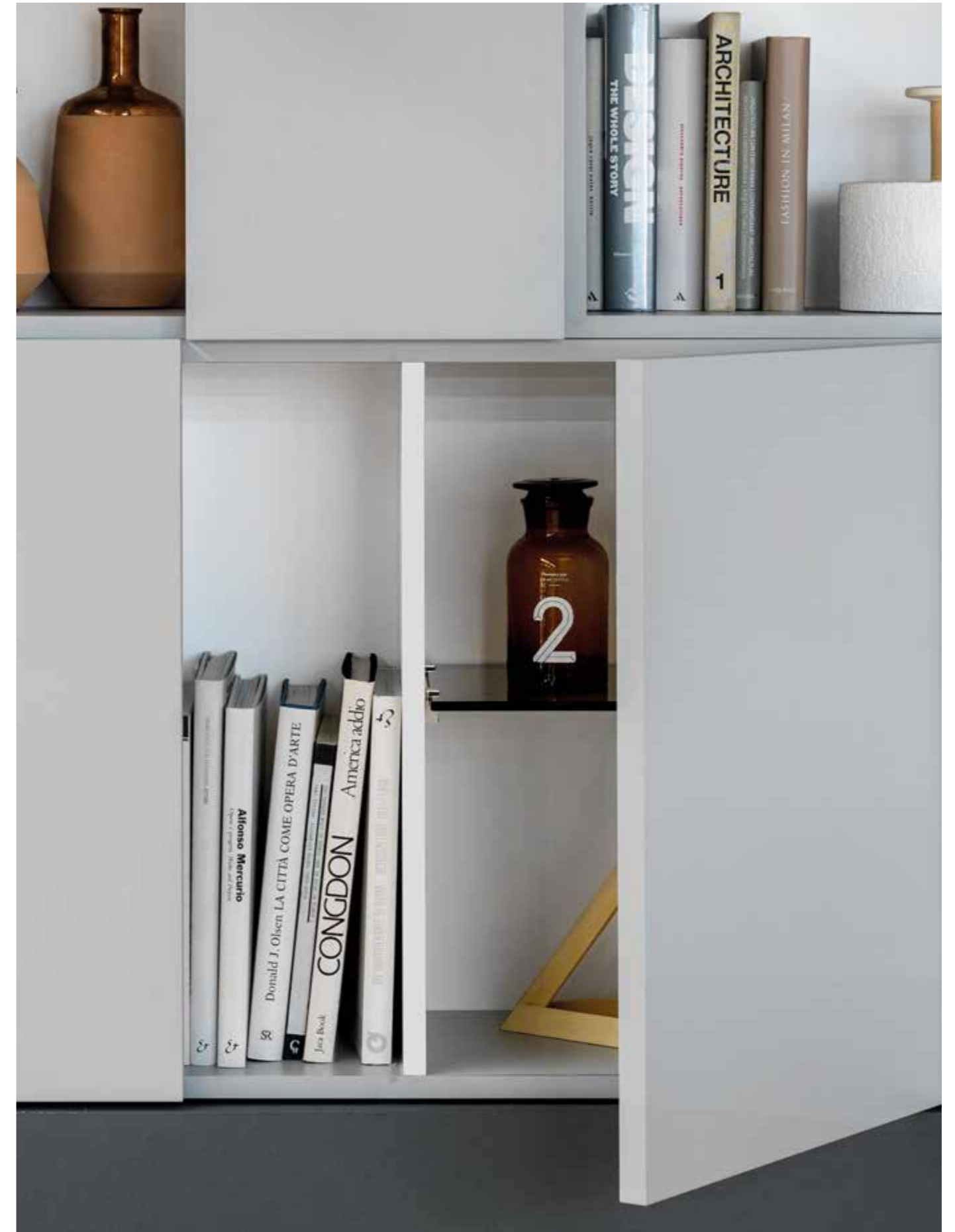



# KITCHEN TECH

Gestione automatizzata del prodotto nella sede produttiva di Falzè di Piave, Treviso.  
Automated product management in our facilities at Falzè di Piave, Treviso.

# FINISHES



## GRES PORCELLANATO PORCELAIN GRES

Per le eccellenti performance tecniche, le superfici Laminam sono ideali negli impieghi più delicati nei quali è necessario garantire la massima igiene e resistenza. Le virtù estetiche e il grande formato, veri e propri plus artistici, garantiscono la continuità della materia in tutto l'ambiente tingendolo con toni naturali e sofisticati.

The excellent technical performance of Laminam surfaces make them ideal for delicate use where hygiene and strength are absolutely necessary. Their good looks and large size are truly artistic pluses and ensure continuity throughout the area, with a sophisticated, natural colour scheme.

LAMINAM

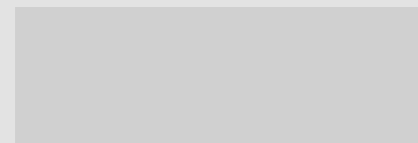

## LACCATO LACQUERED

Il laccato ha una bellezza viva, una tattilità unica. Il laccato opaco è texturizzato mentre il laccato lucido è spazzolato, bordi compresi. Viene lavorato con quattro mani di vernice per una grammatura finale di 120 gr/mq opaco e 240 gr/mq lucido per lato.

Lacquered finishes feature vivacity and unique touch. Mat lacquered surfaces are textured, whereas glossy lacquer is brushed, also on the edges. It is applied with four coats of paint that provide a final grain of 120 g/m<sup>2</sup> for mat and 240 g/m<sup>2</sup> for glossy, per side.



## ECOMALTA®

L'ecomalta utilizza vernici atossiche all'acqua, non sviluppa gas nocivi è esente da leganti idraulici, cemento, calce, gesso, resine epossidiche. Completamente riciclabile. Superficie indistruttibile e impermeabile all'acqua ma permeabile alle molecole del vapore. Per una perfetta realizzazione, vengono eseguiti sei fasi di stesura completamente a mano.

Ecomalta uses non-toxic, water-based paints that do not develop harmful gas and are free of hydraulic binders, cement, lime, chalk or epoxy resins. Fully recyclable. These surfaces are indestructible and impermeable but absorb steam molecules. Six coating stages, carried out entirely by hand, achieve perfection.



## FINITURE FUSION E SATIN FUSION AND SATIN FINISHES

Finitura Fusion e finitura Satin laccate effetto metallo realizzate con sei passaggi manuali su ogni lato. Il risultato è una superficie unica e irripetibile, pregio e bellezza grazie alla luce che crea effetti policromatici.

Metal effect Fusion and Satin lacquered finishes are achieved by manually applying six coats to each side. The result is an attractive, unique surface on which the light creates a multicoloured effect.

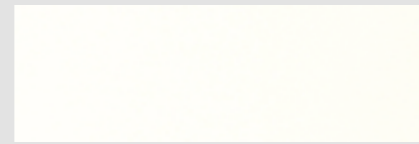

## PIETRA ACRILICA ACRYLIC STONE

La pietra acrilica è un solid surface fabbricato per due terzi circa con idrossido di alluminio e per un terzo con resina acrilica e pigmenti coloranti naturali. L'idrossido d'alluminio conferisce al prodotto un'ottima resistenza meccanica mentre la resina acrilica garantisce igienicità, idoneità al contatto con alimenti, impermeabilità e stabilità del colore nel tempo.

Acrylic stone is a solid surface made up of two thirds aluminium hydroxide and one third acrylic resin coloured with natural pigments. Aluminium hydroxide gives the product excellent mechanical strength, whereas acrylic resin ensures hygiene, suitability for contact with food, waterproofing and colour fastness.

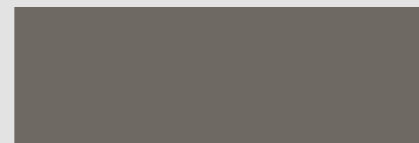

## VETRO GLASS

Materiale d'eccellenza, resistentissimo, è riciclabile all'infinito e mantiene un'igiene sempre perfetta. Il vetro temprato aumenta la resistenza meccanica fino a 5 volte rispetto al vetro comune.

An excellent, strong material that's infinitely recyclable and remains perfectly hygienic. Toughened glass has five times more mechanical resistance than ordinary glass.



## ACCIAIO INOX STAINLESS STEEL

Materiale di alto design, dalla resistenza unica, 100% riciclabile. L'acciaio inox AISI 304 è satinato antimpronta grazie ad una particolare lavorazione.

Design friendly material, extremely robust and 100% recyclable. A special process makes AISI 304 satin stainless steel fingerprint proof.



## LEGNO WOOD

Legni caratterizzati dalla marcata matericità, di grande pregio e dalle finiture naturali che presentano tutta la bellezza delle venature, dei nodi e il particolare effetto sgucciato. L'aspetto tattile e visivo è tipico del legno vissuto, trattato con speciali lavorazioni quando viene utilizzato come piano di lavoro.

The wood we use features great textures and natural finishes that highlight all the beauty of the grain, knots and a special hand-planed effect. The touch and appearance are typical of time-worn wood, specially treated when used as a worktop.

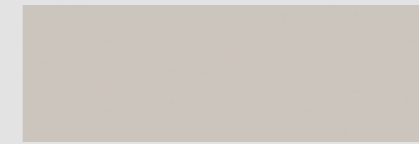

## FENIX®

FENIX NTM® è un materiale innovativo, nanotech, super opaco e soft touch, coniuga raffinate soluzioni estetiche con prestazioni tecnologiche all'avanguardia. La parte esteriore di FENIX NTM® è ottenuta con l'ausilio di nanotecnologie ed è caratterizzata da una superficie trattata con resine acriliche di nuova generazione.

FENIX NTM® is an innovative, nanotech material that's super mat and soft touch. It combines refined good looks with avant garde technological performance. The outer layer of FENIX NTM® is achieved by nanotechnologies and features a surface treated with new generation acrylic resins.

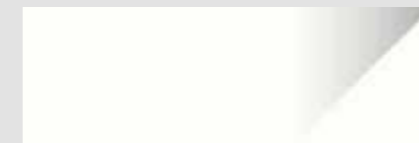

## TECNOLAMINA

La tecnolamina è una superficie innovativa estremamente resistente. Il trattamento superficiale di verniciatura anti-ingiallente rende il colore inalterabile e costante nel tempo e resistente alla luce. Elevato grado di brillantezza per la tecnolamina lux ed elevato grado di opacità per la tecnolamina matt che presenta una sensazione tattile vellutata. La resistenza all'abrasione e agli agenti chimici rende il prodotto estremamente duraturo.

Tecnolamina is an extremely strong, innovative surface. It is treated with non-yellowing paint that makes the colours fast and resistant to light throughout time. Tecnolamina lux is especially bright and Tecnolamina matt has a particularly mat finish that has a velvety feel. Resistance to abrasions and chemicals make this a long life product.



## ECOLACCATO

L'ecolaccato è una finitura realizzata con vernice atossica all'acqua che riduce del 95% l'emissione di solventi inquinanti. I frontali in ecolaccato, sono finiti su tutti i lati con grammatura finale 120 gr/mq. Il risultato è una finitura opaca, morbida come la seta.

Ecolaccato is a finish achieved with non-toxic, water-based paints that reduce emissions of polluting solvents by 95%. Ecolaccato fronts are finished on all sides with a final weight of 120 g/m<sup>2</sup>. The result is a soft and silky mat finish.



## TERMOSTRUTTURATO THERMOSTRUCTURED

I termostrutturati sono robusti, antigraffio, dalla facile pulizia e dalle eccezionali doti di resistenza. Presentano matericità dal perfetto effetto legno sia sul fronte che sul retro dell'anta.

Thermostructured finishes are strong, scratch proof, easy to clean with extremely resistant. They feature a perfect wood effect texture on both the front and back of the door.

# FINISHES

## GRES PORCELLANATO PORCELAIN GRES

### LAMINAM®

Telero

## ECOMALTA®

Antis

## PIETRA ACRILICA ACRYLIC STONE

Telero

## ACCIAIO INOX STAINLESS STEEL

Free Steel

## FENIX®

Telero / Antis

## ECOLACCATO

Lain

## LACCATO LACQUERED

### LACCATO OPACO TEXTURIZZATO TEXTURED MAT LACQUERED

Telero / Antis / Filò / Assim

### LACCATO LUCIDO SPAZZOLATO BRUSHED GLOSSY LACQUERED

Telero / Antis / Assim

### FUSION - LACCATO EFFETTO ACCIAIO FUSION - STEEL EFFECT LACQUERED

Telero / Antis / Filò

### SATIN - LACCATO EFFETTO ACCIAIO SATINATO SATIN - LACQUERED WITH SATIN STEEL EFFECT

Telero / Antis

## VETRO GLASS

### VETRO OPACO MAT GLASS

Telero / Kubic

### VETRO LUCIDO GLOSSY GLASS

Telero / Kubic

## LEGNO WOOD

### ROVERE MATERIA MATERIA OAK

Telero / Antis

### ROVERE TEXTURE TEXTURE OAK

Telero / Antis

### NOCE MATERIA MATERIA WALNUT

Telero / Antis

### EUCALIPTO TERMOTRATTATO THERMOTREATED EUCALYPT

Telero / Antis

### ROVERE GRAFF GRAFF OAK

Antis

## TECNOLAMINA

### TECNOLAMINA MATT TECNOLAMINA MAT

Lain

### TECNOLAMINA LUX TECNOLAMINA LUX

Lain

## TERMOSTRUTTURATO THERMOSTRUCTURED

### ROVERE MATERICO TEXTURED OAK

Lain

### LIGNUM

Lain

### OLMO NT NT ELM

Lain

### TSS IMPRIMÉ

Lain

### TSS CEMENTO TSS CONCRETE

Lain

## MELAMINICO MELAMINE

### MELAMINICO FINITURA TECHNO MELAMINE WITH TECHNO FINISH

Lain

# TELERO FIL033

## FINITURE

### VETRO

VETRO OPACO  
VETRO LUCIDO

### LACCATO

LACCATO OPACO TEXTURIZZATO  
LACCATO LUCIDO SPAZZOLATO  
FUSION - LACCATO EFFETTO ACCIAIO  
SATIN - LACCATO EFFETTO ACCIAIO SATINATO

### LEGNO

ROVERE MATERIA  
ROVERE TEXTURE  
NOCE MATERIA  
EUCALIPTO TERMOTRATTATO

## FINITURE TELAIO

### ALLUMINIO

TITANIO  
NERO ASSOLUTO

## FINISHES

### GLASS

MAT GLASS  
GLOSSY GLASS

### LACQUERED

TEXTURED MAT LACQUERED  
BRUSHED GLOSSY LACQUERED  
FUSION - STEEL EFFECT LACQUERED  
SATIN - LACQUERED WITH SATIN STEEL EFFECT

### WOOD

MATERIA OAK  
TEXTURE OAK  
MATERIA WALNUT  
THERMOTREATED EUCALYPT

## FRAME FINISHES

### ALUMINIUM

TITANIUM  
ABSOLUT BLACK

### FENIX®

**GRES PORCELLANATO**  
LAMINAM®

### PIETRA ACRILICA

### FENIX®

**PORCELAIN GRES**  
LAMINAM®

### ACRYLIC STONE

## FIL033

Gola con frontali  
lato maniglia sagomato  
Groove profile with  
shaped fronts

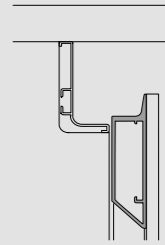

Anta Telero, dettaglio telaio interno:  
il bordo perimetrale interno in  
alluminio anodizzato con elegante  
lavorazione millerighe, è inclinato  
a 45° per facilitare la pulizia  
e rendere il frontale più piacevole.  
Telero door, detail of internal frame:  
the internal surround in smart,  
finely striped anodised aluminium,  
slopes 45° to facilitate cleaning and  
add to the attractiveness of the front.

# ANTIS

MULTISYSTEM  
FILO  
FILO33

## FINITURE

### LACCATO

LACCATO OPACO TEXTURIZZATO  
LACCATO LUCIDO SPAZZOLATO  
FUSION - LACCATO EFFETTO ACCIAIO  
SATIN - LACCATO EFFETTO ACCIAIO SATINATO

### LEGNO

ROVERE MATERIA  
ROVERE TEXTURE  
NOCE MATERIA  
EUCALIPTO TERMOTRATTATO  
ROVERE GRAFF

### FENIX®

### ECOMALTA®

## FINISHES

### LACQUERED

TEXTURED MAT LACQUERED  
BRUSHED GLOSSY LACQUERED  
FUSION - STEEL EFFECT LACQUERED  
SATIN - LACQUERED WITH SATIN STEEL EFFECT

### WOOD

MATERIA OAK  
TEXTURE OAK  
MATERIA WALNUT  
THERMOTREATED EUCALYPT  
GRAFF OAK

### FENIX®

### ECOMALTA®

## MULTISYSTEM

Frontali con maniglia  
Fronts with handle

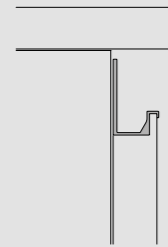

maniglia PRO  
PRO handle

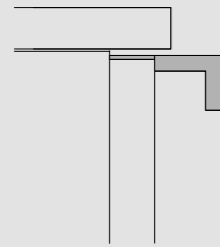

maniglia FLY  
FLY handle

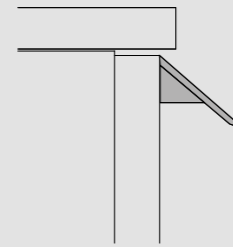

maniglie a ridosso  
close-fitting handles

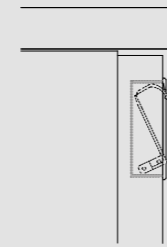

maniglie incasso  
built-in handles

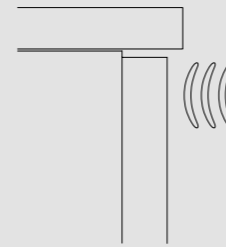

push-pull  
push-pull



maniglia PRO / PRO handle



maniglia FLY / FLY handle

# ANTIS

MULTISYSTEM  
FILO  
FILO33

## FILO

Gola con frontali dritti  
Groove profile with straight fronts

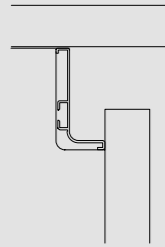

anta dritta  
straight door



## FILO33

Gola con frontali  
lato maniglia inclinato 33°  
Groove profile with  
33° inclined fronts

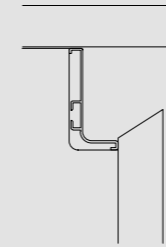

anta 33  
door 33



# ANTIS

MULTISYSTEM  
FILO  
FILO33

Antis finitura fusion,  
taglio anta 33°  
frontali e coprifianchi a 45°  
Antis with fusion finish,  
door with 33° cut. Fronts and  
finishing panel with 45° cut



Antis finitura ecomalta,  
taglio anta 33°  
frontali, top e coprifianchi a 45°  
Antis with ecomalta finish,  
door with 33° cut. Fronts, tops  
and finishing panels with 45° cut





# LAIN

MULTISYSTEM  
FILO  
FILO33

## FINITURE

### TERMOSTRUTTURATO

ROVERE MATERICO  
LIGNUM  
OLMO NT  
TSS IMPRIMÉ  
TSS CEMENTO

### ECOLACCATO

### MELAMINICO

MELAMINICO FINITURA TECHNO

### TECNOLAMINA

TECNOLAMINA MATT  
TECNOLAMINA LUX

## FINISHES

### THERMOSTRUCTURED

TEXTURED OAK  
LIGNUM  
NT ELM  
TSS IMPRIMÉ  
TSS CONCRETE

### ECOLACCATO

### MELAMINE

MELAMINE WITH TECHNO FINISH

### TECNOLAMINA

TECNOLAMINA MAT  
TECNOLAMINA LUX

## MULTISYSTEM

Frontali con maniglia  
Fronts with handle

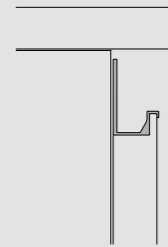

maniglia PRO  
PRO handle

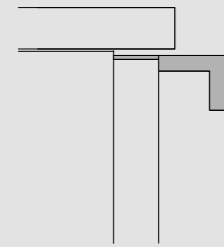

maniglia FLY  
FLY handle

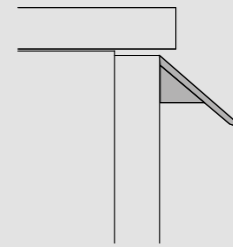

maniglie a ridosso  
close-fitting handles

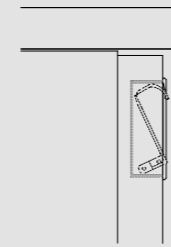

maniglie incasso  
built-in handles

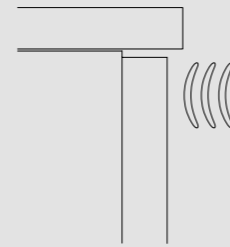

push-pull  
push-pull



maniglia PRO / PRO handle



maniglia DIAGO / DIAGO handle

**LAIN** MULTISYSTEM  
FILO  
FILO33

**FILO**

Gola con frontali dritti  
Groove profile with straight fronts

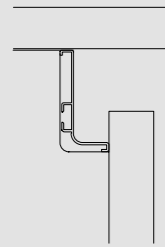

anta dritta  
straight door

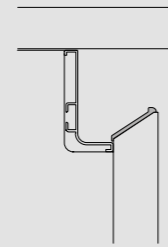

anta + maniglia M33  
door + M33 handle

**FILO33**

Gola con frontali  
lato maniglia inclinato 33°  
Groove profile with  
33° inclined fronts

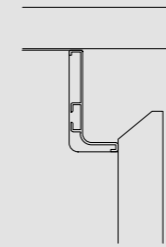

anta 33  
door 33



# FILÒ

MULTISYSTEM  
FILO

## FINITURE

### LACCATO

LACCATO OPACO TEXTURIZZATO  
FUSION - LACCATO EFFETTO ACCIAIO

## FINISHES

### LACQUERED

TEXTURED MAT LACQUERED  
FUSION - STEEL EFFECT LACQUERED

## MULTISYSTEM

Frontali con maniglia  
Fronts with handle

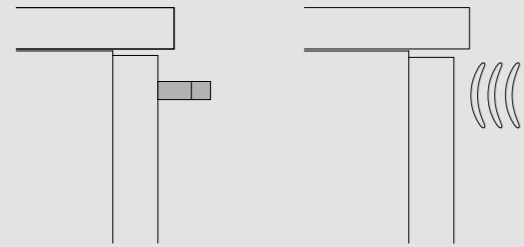

maniglie a ridosso  
close-fitting handles

push-pull  
push-pull

## FILO

Gola con frontali dritti  
Groove profile with straight fronts

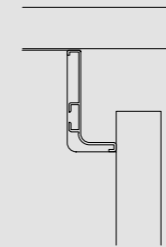

anta dritta  
straight door



maniglia TAG / TAG handle



# KUBIC FIL033

## FINITURE

**VETRO**  
 VETRO OPACO  
 VETRO LUCIDO

## FINISHES

**GLASS**  
 MAT GLASS  
 GLOSSY GLASS

## FIL033

Gola con frontali  
 lato maniglia inclinato 33°  
 Groove profile with  
 33° inclined fronts

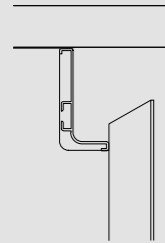

anta 33  
 door 33



La ante Kubic sono totalmente idrorepellenti, indifferenti all'umidità e al calore. Il brevetto costruttivo delle ante assicura doti di resistenza meccanica fino a 5 volte rispetto al comune. Il vetro e l'alluminio sono materiali ecologici per eccellenza, sono infatti riciclabili all'infinito.  
 Kubic doors are entirely waterproof and not affected by humidity or heat. These patented doors are five times stronger than other popular doors. Glass and aluminium are ecological materials par excellence as they can be recycled infinitely.

# ASSIM MULTISYSTEM

## FINITURE

### LACCATO

LACCATO OPACO TEXTURIZZATO  
LACCATO LUCIDO SPAZZOLATO

## FINISHES

### LACQUERED

TEXTURED MAT LACQUERED  
BRUSHED GLOSSY LACQUERED

## MULTISYSTEM

Frontali con maniglia  
Fronts with handle

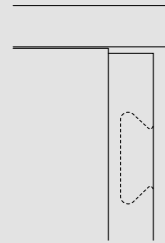

maniglia integrata  
integrated handle



Cassetiera con  
maniglia centrale  
Drawer unit with  
central handle

# FREE STEEL

MULTISYSTEM  
FILO

## FINITURE

### ACCIAIO INOX

## MULTISYSTEM

Frontali con maniglia  
Fronts with handle

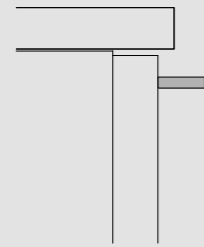

maniglie a ridosso  
close-fitting handles

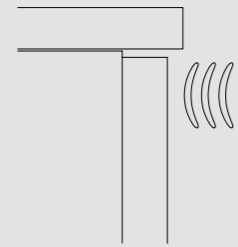

push-pull  
push-pull



maniglia REGULA / REGULA handle

## FINISHES

### STAINLESS STEEL

## FILO

Gola con frontali dritti  
Groove profile with straight fronts

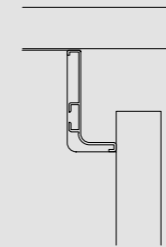

anta dritta  
straight door



La forza, la resistenza e la durata dell'acciaio inox satinato AISI 304 antimpronta per il frontale e il perimetro dell'anta, la bellezza e la leggerezza dell'alluminio sul retro anta, con raccordi originali sugli angoli.  
The power of the strength and duration of fingerprint proof satin stainless steel for the front and perimeter door, the beauty and the lightweight aluminum on back door with original fittings on corners.



CONCEPT AND GRAPHIC DESIGN  
**valentinicesarottiassociati**

PHOTO  
Ezio Prandini  
Federico Zattarin

IMAGES  
Alberto Massi Mauri

STYLING  
Luigina Pilloni

COLOUR SEPARATION  
CD Cromo

PRINT  
Grafiche Antiga

EDITION  
CAT 0118 IT UK

I DIVANI, LE POLTRONE  
E I COMPLEMENTI  
PRESENTI NEL CATALOGO  
SONO DI **DÉSIRÉE**  
THE SOFAS, ARMCHAIRS  
AND COMPLEMENTS  
IN THE CATALOGUE  
ARE BY **DÉSIRÉE**



**100% MADE IN ITALY**

**Euromobil**

Via Circonvallazione, 21  
31020 Falzè di Piave - TV - Italy  
Tel. + 39 04389861  
info@euromobil.it

**Zalf**

Via Marosticana, 9  
31010 Maser - TV - Italy  
Tel. + 39 04239255  
info@zalf.com

désirée

Via Piave, 25  
31028 Tezze di Piave - TV - Italy  
Tel. + 39 0438 2817  
info@gruppoeuromobil.com

GRUPPOEUROMOBIL.COM





